

WINE EDUCATION CENTER NAPA VALLEY COLLEGE

ADDENDUM NUMBER 1

PROJECT ADDRESS
**2277 Napa Vallejo Hwy
Napa, CA 94558**

OWNER
NAPA VALLEY COLLEGE

DATE
MARCH 6, 2024

TLCD PROJECT NUMBER
21062.00

DSA APPLICATION NUMBER:
01-120890

Note: The following changes, modifications and additions to the Project Manual and Drawings described within this Addendum are made a part thereof and are subject to all of the requirements thereof as if originally specified.

ADDENDUM NUMBER 1
WINE EDUCATION CENTER
NAPA VALLEY COLLEGE
2277 Napa Vallejo Hwy
Napa, CA 94558

DSA APPLICATION #01-120890

STAMPS, SIGNATURES AND APPROVALS

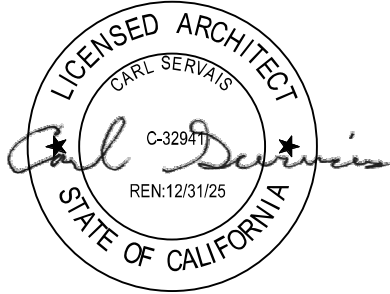

ARCHITECT
Carl Servais
C32941



CIVIL ENGINEER
Paul V. Bartholow
40512

THIS PAGE INTENTIONALLY LEFT BLANK

ADDENDUM NUMBER 1

To the Plans and Specifications for:

WINE EDUCATION CENTER NAPA VALLEY COLLEGE

DSA File No. 28-C1
DSA Application No. 01-120890

Date: March 6, 2024

SPECIFICATIONS

- 1.1 CHANGE TO 00 01 10 TABLE OF CONTENTS
 - A. CHANGE Title from “CONTRACTING REQUIREMENTS” to “PROCUREMENT AND CONTRACTING REQUIREMENTS”.
 - B. DELETE Section 00 72 00 General Conditions and REPLACE with “Construction Bid Documents (CCD)”.
 - C. DELETE Section 00 73 00 Supplementary Conditions and REPLACE with section “00 01 21 Supplemental Conditions”.
 - D. ADD Section “00 31 19 Existing Condition Information”.
 - E. ADD Section “00 31 32 Geotechnical Data”.
- 1.2 ADD SPECIFICATION SECTION 00 31 19 EXISTING CONDITION INFORMATION
- 1.3 ADD SPECIFICATION SECTION 00 31 32 GEOTECHNICAL DATA.

DRAWINGS

- 1.4 CHANGE TO DRAWING G-001 – TITLE SHEET:
 - A. ADD Drawing C-504 DETAILS to the SHEET INDEX.

-
- 1.5 ADD TO DRAWING C-103 – PHASE 1 UTILITY PLAN FIRE LINE & EAST DROP OFF:
- A. ADD Fire line extension as indicated on the drawing.
- 1.6 ADD DRAWING C-504 -DETAILS:
- A. ADD Fire line extension and appurtenance details as indicated on the drawing.
- 1.7 CHANGE DRAWING A-101 - PARTIAL SITE PLAN – DEMOLITION WORK:
- A. ADD Notation to salvage and existing artwork sculpture and deliver to the College. This change supersedes note 'R' on drawings C-002.
- B. ADD Detail 2 - ART SCULPTURE with image of existing sculpture for salvage.
- 1.8 CHANGE DRAWING A-253 – INTERIOR ELEVATIONS – PHASE 2:
- A. CHANGE Wall base detail at north, east and west walls from detail 10/A-561 to detail ASK1-AD1 WOOD BASE AT HOSPITALITY.
- 1.9 CHANGE TO DRAWING A-601 – DOOR SCHEDULE:
- A. CHANGE Door 117A material from wood to hollow metal.
- B. CHANGE Door 117B material from hollow metal to wood.
- C. CHANGE Door 116D remarks for exterior color from “RAINSCREEN” to “BOARD & BATTEN” color.

ATTACHMENTS:

SPECIFICATIONS:

00 01 10 Table of Contents
Construction Bid Documents (CCD)
00 01 21 Supplemental Conditions
00 31 19 Existing Condition Information
00 31 32 Geotechnical Data

DRAWINGS:

G-001 TITLE SHEET
C-103 PHASE 1 UTILITY PLAN FIRE LINE
C-504 DETAILS
A-101 PARTIAL SITE PLAN - DEMOLITION
A-253 INTERIOR ELEVATIONS – PHASE 2
A-601 ROOM FINISH SCHEDULE, DOOR TYPES & STOREFRONT/CURTAINWALL TYPES
ASK1-AD1 WOOD BASE AT HOSPITALITY

END OF ADDENDUM NUMBER 1

THIS PAGE LEFT INTENTIONALLY BLANK

SECTION 00 01 10

TABLE OF CONTENTS

PROJECT MANUAL
INTRODUCTORY INFORMATION

Document 00 01 10 Table of Contents

PROCUREMENT AND CONTRACTING REQUIREMENTS
~~CONTRACTING REQUIREMENTS~~

Document ~~00 72 00~~ ~~General Conditions~~
Construction Bid Documents (CCD)
Table of Contents
Notice Inviting Bids
Instructions to Bidders
Bid Proposal Form
Subcontractor List Form
Worker's Compensation Certificate
Non-collusion Declaration
Bid Bond
Bidder's Questionnaire
Contract
General Conditions
Notice of Award
Notice to Proceed
Performance Bond & Payment Bond
Iran Contracting Act Certificate
Compliance with Economic Sanctions Certification
~~00 73 00~~ ~~Supplementary Conditions~~
00 01 21 **Supplemental Conditions**
00 31 19 **Existing Condition Information**
00 31 32 **Geotechnical Data**

SPECIFICATIONS GROUP

DIVISION 01 – GENERAL REQUIREMENTS

Section 01 10 00 Summary of Work
 01 25 00 Substitution Procedures
 01 26 00 Contract Modification Procedures
 01 29 00 Payment Procedures
 01 31 00 Project Management and Coordination
 01 32 00 Construction Progress Documentation
 01 33 00 Submittal Procedures
 01 40 00 Quality Requirements
 01 42 00 References
 01 50 00 Temporary Facilities and Controls
 01 56 39 Temporary Tree and Plant Protection
 01 57 23 Temporary Stormwater Pollution Control
 01 60 00 Product Requirements

01 73 00	Execution
01 74 19	Construction Waste Management and Disposal
01 77 00	Closeout Procedures
01 78 23	Operation and Maintenance
01 78 39	Project Record Documents
01 79 00	Demonstration and Training
01 81 13	Sustainable Design Requirements - CALGreen Non-Residential Mandatory

DIVISION 02 – EXISTING CONDITIONS

Section	02 41 10	Structure Demolition
---------	----------	----------------------

DIVISION 03 – CONCRETE

Section	03 10 00	Concrete Forming and Accessories
	03 20 00	Concrete Reinforcing
	03 30 00	Cast-In-Place Concrete
	03 35 15	Sealed Concrete Flooring

DIVISION 04 – MASONRY

Not Used

DIVISION 05 – METALS

Section	05 12 00	Structural Steel Framing
	05 12 10	Architecturally Exposed Structural Steel
	05 50 00	Metal Fabrications
	05 70 00	Decorative Metal
	05 70 05	Landscape Metalwork

DIVISION 06 – WOOD, PLASTICS, AND COMPOSITES

Section	06 10 00	Rough Carpentry
	06 17 33	Wood I-Joists
	06 20 00	Finish Carpentry
	06 40 00	Architectural Woodwork

DIVISION 07 – THERMAL AND MOISTURE PROTECTION

Section	07 13 00	Sheet Waterproofing
	07 21 00	Thermal Insulation
	07 25 00	Weather-Resistive Barriers
	07 26 00	Below-Grade Vapor Retarder
	07 41 15	Manufactured Standing Seam Roofing
	07 46 20	Wood Siding
	07 46 50	GFRC Façade System
	07 54 25	Elastomeric TPO Membrane Roofing
	07 60 00	Flashing and Sheet Metal
	07 72 00	Roof Hatches
	07 84 00	Firestopping

07 90 00	Joint Sealants
07 95 00	Expansion Joint Cover Assemblies

DIVISION 08 – OPENINGS

Section	08 11 10	Hollow Metal Doors and Frames
	08 14 00	Wood Doors
	08 35 40	Sliding Aluminum and Glass Walls
	08 41 00	Entrances and Storefronts
	08 44 20	Glazed Curtain wall Systems
	08 71 00	Door Hardware
	08 71 15	Low Energy Door Operators
	08 80 00	Glazing

DIVISION 09 – FINISHES

Section	09 21 00	Gypsum Board Assemblies
	09 24 00	Portland Cement Plaster
	09 30 00	Tiling
	09 51 00	Acoustical Ceilings
	09 65 10	Resilient Base
	09 65 20	Resilient Tile Flooring
	09 65 25	Static Resistant Flooring
	09 68 10	Tile Carpeting
	09 77 30	Fiberglass Wall Panels
	09 90 00	Painting and Coating
	09 96 70	High Performance Coating

DIVISION 10 – SPECIALTIES

Section	10 14 00	Signage
	10 21 00	Metal Toilet Compartments
	10 22 20	Operable Partitions
	10 28 00	Toilet Accessories
	10 44 00	Fire Extinguisher Cabinets
	10 56 10	Metal Storage Shelving

DIVISION 11 – EQUIPMENT

Section	11 31 00	Appliances
	11 53 13	Laboratory Fume Hoods
	11 53 43	Lab Sinks Mechanical Electrical Fixtures

DIVISION 12 – FURNISHINGS

Section	12 24 10	Electric Window Shades
	12 35 53	Laboratory Casework System and Accessories
	12 36 61	Solid Surfacing Countertops
	12 48 15	Recessed Entry Grilles

DIVISION 13 – SPECIAL CONSTRUCTION

Not used.

DIVISION 14 – CONVEYING EQUIPMENT

Not used.

DIVISION 21 – FIRE SUPPRESSION

Section 21 00 00 Fire Suppression

DIVISION 22 – PLUMBING

Section 22 00 00 Plumbing

DIVISION 23 – HEATING VENTILATING AND AIR CONDITIONING

Section 23 00 00 Mechanical

DIVISION 26 – ELECTRICAL

Section 26 05 00 Basic Electrical Requirements
 26 05 13 Medium Voltage Distribution
 26 08 00 Testing
 26 12 02 Three-Phase Padmounted Transformer
 26 24 00 Service and Distribution System
 26 27 00 Basic Electrical Materials and Methods
 26 31 01 Photovoltaic System
 26 32 01 Lithium Iron Phosphate Battery Storage
 26 51 01 Lighting
 26 56 01 Site Lighting
 26 57 00 Low Voltage Lighting Control Systems

DIVISION 27 – COMMUNICATIONS

Section 27 00 00 Telecommunications Systems
 27 51 03 Assisted Listening System

DIVISION 28 - ELECTRONIC SAFETY AND SECURITY

Section 28 31 00 Fire Alarm System with Voice Evacuation

DIVISION 31 – EARTHWORK

Section 31 10 00 Site Preparations
 31 10 01 Plant Protection
 31 20 00 Earthwork
 31 23 16 Trenching, Backfilling, Compaction

DIVISION 32 – EXTERIOR IMPROVEMENTS

Section 32 12 16 Asphalt Concrete Paving and Base
 32 12 23 Pavement Markings and Signs
 32 13 12 Landscape Concrete
 32 14 12 Concrete Unit Paving
 32 16 00 Concrete Curb, Gutter and Sidewalk
 32 17 26 Cast-In-Place Detectable/Tactile Warning Surfaces

32 31 14	Vinyl Coated Chain Link Fence & Gates
32 33 00	Site Furnishings
32 84 00	Irrigation
32 90 00	Planting

DIVISION 33 –UTILITIES

Section	33 11 00	Water Utility Distribution Piping
	33 30 00	Sanitary Sewerage Utilities
	33 40 00	Site Drainage

END OF SECTION

THIS PAGE LEFT INTENTIONALLY BLANK

CONSTRUCTION BID DOCUMENTS (CCD)

TABLE OF CONTENTS

1. Notice Inviting Bids
2. Instructions to Bidders
3. Bid Proposal Form
4. Subcontractor List Form
5. Workers' Compensation Certificate
6. Non-collusion Declaration
7. Bid Bond
8. Bidders' Questionnaire
9. Contract
10. General Conditions
11. Notice of Award
12. Notice to Proceed
13. Performance Bond and Payment Bond
14. Iran Contracting Act Certification
15. Compliance with Economic Sanctions Certification

NOTICE INVITING BIDS

1. Notice is hereby given that the Governing Board of the Napa Valley College District (“District”), of the County of Napa, State of California, will receive sealed bids for the Napa Valley College Wine Education Center Project (“Project”) up to but no later than 2 PM on Thursday, April 25th, 2024, and will thereafter publicly opened and read aloud the bids. All bids shall be received at the Napa Valley College Office #4103 at 2277 Napa-Vallejo Hwy, Napa, California.
2. Each bid shall be completed on the Bid Proposal Form included in the Contract Documents, and must conform and be fully responsive to this invitation, the plans and specifications and all other Contract Documents. Copies of the Contract Documents are available for examination at the office of the Napa Valley College and will be available on the Napa Valley College website.
3. Each bid shall be accompanied by cash, a cashier's or certified check, or a bidder's bond executed by a surety licensed to do business in the State of California as a surety, made payable to the District, in an amount not less than ten percent (10%) of the maximum amount of the bid. The check or bid bond shall be given as a guarantee that the bidder to whom the contract is awarded will execute the Contract Documents and will provide the required payment and performance bonds and insurance certificates within ten (10) days after the notification of the award of the contract.
4. The successful bidder shall comply with the provisions of the Labor Code pertaining to payment of the generally prevailing rate of wages and apprenticeships or other training programs. The Department of Industrial Relations has made available the general prevailing rate of per diem wages in the locality in which the work is to be performed for each craft, classification or type of worker needed to execute the contract, including employer payments for health and welfare, pension, vacation, apprenticeship and similar purposes. Copies of these prevailing rates are available to any interested party upon request and are online at <http://www.dir.ca.gov/DLSR>. The Contractor and all Subcontractors shall pay not less than the specified rates to all workers employed by them in the execution of the Contract. It is the Contractor's responsibility to determine any rate change.
5. The schedule of per diem wages is based upon a working day of eight hours. The rate for holiday and overtime work shall be at least time and one half.
6. The substitution of appropriate securities in lieu of retention amounts from progress payments in accordance with Public Contract Code §22300 is permitted.
7. Pursuant to Public Contract Code §4104, each bid shall include the name and location of the place of business of each subcontractor who shall perform work or service or fabricate or install work for the contractor in excess of one-half of one percent (1/2 of 1%) of the bid price. The bid shall describe the type of the work to be performed by each listed subcontractor.

8. No bid may be withdrawn for a period of sixty (60) days after the date set for the opening for bids except as provided by Public Contract Code §§5100 *et seq.* The District reserves the right to reject any and all bids and to waive any informalities or irregularities in the bidding.
9. Minority, women, and disabled veteran contractors are encouraged to submit bids. This bid is subject to Disabled Veteran Business Enterprise requirements.
10. This project is subject to prevailing wage requirements and bidder and its subcontractors are required to pay all workers employed for the performance of this project no less than the applicable prevailing wage rate for each such worker. If this project is for a public works project over \$25,000 or for a maintenance project over \$15,000, bidder acknowledges that the project is subject to compliance monitoring and enforcement by the California Department of Industrial Relations in accordance with California Labor Code sections 1725.5 and 1770 *et seq.*
11. Each bidder shall possess at the time the bid is awarded the following classification(s) of California State Contractor's license: Class B, General Building Contractor.
12. By approving these bid documents, the Governing Board finds that the Napa Valley College Wine Education Center Project is substantially complex and unique and therefore requires a retention amount of 10%.
13. X Bidder's Conference. A mandatory bidders' conference will be held at 2277 Napa-Vallejo Hwy, Napa Valley College campus, at the Trefethen Viticulture Building 3200A project site at 11 AM for the purpose of acquainting all prospective bidders with the Contract Documents and the Project site. Failure to attend the conference will result in the disqualification of the bid of the non-attending bidder.

_____ No Bidders' Conference.

NAPA VALLEY COLLEGE DISTRICT

By: James Reeves, Asst. Superintendent Vice President of Administrative Services

DATED: March 6, 2024

Publication Dates: Not applicable.

INSTRUCTIONS TO BIDDERS

Each bid submitted to the Napa Valley College District (“District”) for the Napa Valley College Wine Education Center Project (“Project”) shall be in accordance with the following instructions and requirements, which are part of the Contract Documents for this Project.

1. Deadline For Receipt of Bids. Each bid shall be sealed and submitted to the District Superintendent or designee no later than 2 PM on April 25th, 2024. The District suggests that bids be hand delivered in order to ensure their timely receipt. Any bids received after the time stated, regardless of the reason, shall be returned, unopened, to the bidder.

2. Bidders’ Conference. A mandatory bidders’ conference will be held on March 20th, 2024 at 11 AM for the purpose of acquainting all prospective bidders with the Contract Documents and the Project site. It is imperative that all prospective bidders attend this conference. The failure to attend the conference will result in the disqualification of the bid of the non-attending bidder.

3. Requests for Information. A bidder’s failure to request clarification or interpretation of an apparent error, inconsistency or ambiguity in the Contract Documents waives that bidder’s right to thereafter claim entitlement to additional compensation based upon an ambiguity, inconsistency, or error, which should have been discovered by a reasonably prudent Contractor, subject to the limitations of Public Contract Code §1104. Any questions relative to the bid shall be in writing and directed to Ken Burroughs at KBurroughs@Kitchell.com. These requests shall be submitted to the District and Kitchell at least five working days prior to the date the bid is due.

4. Bid Proposal Forms. All bid proposals shall be made on the form provided by the District. All items on the form shall be filled out in ink. Numbers should be stated in figures, and the signatures of all individuals must be in long hand. The completed form should be without interlineations, alterations, or erasures

5. Execution of Forms. Each bid shall give the full business address of the bidder and must be signed by the bidder or bidder’s authorized representative with his or her usual signature. Bids by partnerships must furnish the full names of all partners and must be signed in the partnership name by a general partner with authority to bind the partnership in such matters. Bids by corporations must be signed with the legal name of the corporation, followed by the signature and designation of the president, secretary, or other person authorized to bind the corporation in this matter. The name of each person signing shall also be typed or printed below the signature. When requested by the District, satisfactory evidence of the authority of the officer signing on behalf of the corporation or partnership shall be furnished. A bidder’s failure to properly sign required forms may result in rejection of the bid. All bids must include the bidder’s contractor license number(s) and expiration date(s).

6. Bid Security. Bid proposals shall be accompanied by a certified or cashier’s check or bid bond for an amount not less than ten percent (10%) of the bid amount, payable to the District. A

bid bond shall be secured from an admitted surety company, licensed in the State of California, and satisfactory to the District. The bid security shall be given as a guarantee that the bidder will enter into the Contract if awarded the work, and in the case of refusal or failure to enter into the Contract within ten (10) calendar days after notification of the award of the Contract or failure to provide the payment and performance bonds and proof of insurance as required by the Contract Documents, the District shall have the right to award the Contract to another bidder and declare the bid security forfeited. The District reserves the right to pursue all other remedies in law or equity relating to such a breach including, but not limited to, seeking recovery of damages for breach of contract. Failure to provide bid security, or bid security in the proper amount, shall result in rejection of the bid.

7. Withdrawal of Bid Proposals. Bid proposals may be withdrawn by the bidders prior to the time fixed for the opening of bids, but may not be withdrawn for a period of sixty (60) days after the opening of bids, except as permitted pursuant to Public Contract Code §5103.
8. Addenda or Bulletins. The District reserves the right to issue addenda or bulletins prior to the opening of the bids subject to the limitations of Public Contract Code §4104.5. Any addenda or bulletins issued prior to bid time shall be considered a part of the Contract Documents.
9. Bonds. The successful bidder shall be required to submit payment and performance bonds as specified in and using the bond forms included with the Contract Documents. All required bonds shall be based on the maximum total contract price as awarded, including additive alternates, if applicable.
10. Rejection of Bids and Award of Contract. The District reserves the right to waive any irregularities in the bid and reserves the right to reject any and all bids. The Contract will be awarded, if at all, within sixty (60) calendar days after the opening of bids to the lowest responsible and responsive bidder, subject to Governing Board approval. The time for awarding the Contract may be extended by the District with the consent of the lowest responsible, responsive bidder.
11. Execution of Contract. The successful bidder shall, within ten (10) calendar days of the Notice of Award of the Contract, sign and deliver to the District the executed contract along with the bonds and certificates of insurance required by the Contract Documents. In the event the successful bidder fails or refuses to execute the Contract or fails to provide the bonds and certificates as required, the District may declare the bidder's bid deposit or bond forfeited as liquidated damages, and may award the work to the next lowest responsible, responsive bidder, or may reject all bids and, in its sole discretion, call for new bids. In all cases, the District reserves the right, without any liability, to cancel the award of Contract at any time prior to the full execution of the Contract.
12. Drawings and Specifications. All drawings, specifications and other documents used or prepared during the project shall be the exclusive property of the District.
13. Evidence of Responsibility. Upon the request of the District, a bidder shall submit promptly to the District satisfactory evidence showing the bidder's financial resources, the bidder's

experience in the type of work being required by the District, the bidder's availability to perform the Contract and any other required evidence of the bidder's qualifications and responsibility to perform the Contract. The District may consider such evidence before making its decision to award the Contract. Failure to submit requested evidence may result in rejection of the bid.

14. Taxes. Applicable taxes shall be included in the bid prices.
15. Bid Exceptions. Bid exceptions are not allowed. If the Bidder has a comment regarding the bid documents or the scope of work, the Bidder shall submit those comments to the District for evaluation at least five working days prior to the opening of the bids. No oral or telephonic modification of any bid submitted will be considered and a sealed written modification may be considered only if received prior to the opening of bids. E-mailed or faxed bids or modifications will not be accepted.
16. Discounts. Any discounts which the bidder desires to provide the District must be stated clearly on the bid form itself so that the District can calculate the net cost of the bid proposal. Offers of discounts or additional services not delineated on the bid form will not be considered by the District in the determination of the lowest responsible responsive bidder.
17. Quantities. The quantities shown on the plans and specifications are approximate. The District reserves the right to increase or decrease quantities as desired.
18. Prices. Bidders must quote prices F.O.B. unless otherwise noted. Prices should be stated in the units specified and bidders should quote each item separately.
19. Samples. On request, samples of the products being bid shall be furnished to the District.
20. Special Brand Names/Substitutions. In describing any item, the use of a manufacturer or special brand does not restrict bidding to that manufacturer or special brand, but is intended only to indicate quality and type of item desired, except as provided in §3400 of the Public Contract Code. Substitute products will be considered either prior to or after the award of the Contract in accordance with §3400 and as set forth in either the Supplemental Conditions or the Specifications. All data substantiating the proposed substitute as an "equal" item shall be submitted with the written request for substitution. The District reserves the right to make all final decisions on product and vendor selection.
21. Container Costs and Delivery. All costs for containers shall be borne by the bidder. All products shall conform to the provisions set forth in the federal, county, state and city laws for their production, handling, processing and labeling. Packages shall be so constructed to ensure safe transportation to the point of delivery.
22. Bid Negotiations. A bid response to any specific item of the bid using terms such as "negotiable," "will negotiate," or similar phrases, will be considered non-responsive.

23. Prevailing Law. In the event of any conflict or ambiguity between these instructions and state or federal law or regulations, the latter shall prevail. All equipment to be supplied or services to be performed under the bid proposal shall conform to all applicable requirements of local, state and federal law, including, but not limited to, Labor Code §§1771, 1778 and 1779.
24. Allowances. An “allowance” means an amount included in the bid proposal for work that may or may not be included in the Project, depending on conditions that will become known only after the Project is underway.
25. Subcontractors. Pursuant to the Subletting and Subcontracting Fair Practices Act, Public Contract Code §§4100-4114, every bidder shall, on the enclosed Subcontractor List Form, set forth:
 - a. The name and location of the place of business of each Subcontractor who will perform work or labor or render service to the bidder in or about the work or fabricate and install work in an amount in excess of one-half (1/2) of the one percent (1%) of the bidder's total bid.
 - b. If the bidder fails to specify a Subcontractor for any portion of the work to be performed under the Contract in excess of one-half (1/2) of one percent (1%) of the bidder's total bid, bidder agrees that bidder is fully qualified to and shall perform that portion of the work. The successful bidder shall not, without the written consent of the District or compliance with Public Contract Code §§4100 - 4114, either:
 - 1) Substitute any person as Subcontractor in place of the Subcontractor designated in the original bid;
 - 2) Permit any subcontract to be voluntarily assigned or transferred or allow the work to be performed by anyone other than the original Subcontractor listed in the bid; or
 - 3) Sublet or subcontract any portion of the work in excess of one-half (1/2) of one percent (1%) of the total bid as to which the bidder's original bid did not designate a Subcontractor.
26. Examination of Contract Documents and Work Site. Before submitting a bid proposal, all bidders shall carefully examine the Contract Documents, including the plans and specifications, shall visit the site of the proposed work, and shall fully inform themselves of all conditions in and about the work site, as well as applicable federal, state and local laws and regulations that may affect the work. No bidder shall visit the site without prior authorization of the District. Bidders shall contact the District Superintendent or designee for coordination of site visits.
27. Form and Approval of Contract. The Contract Documents must be approved by the Governing Board of the District and its legal counsel. The bidder selected by the District shall execute the contract provided by the District.

28. Licenses and Permits. Each bidder shall at all times possess all appropriate and required licenses or other permits to perform the work as identified in the Contract Documents. Upon request, each bidder shall furnish the District with evidence demonstrating possession of the required licenses or permits.
29. Denial of Right to Bid. Contractors or Subcontractors who have violated state law governing public works shall be denied the right to bid on this public works contract pursuant to Labor Code §1777.7.
30. Bidders Interested in More Than One Bid. No person, firm, or corporation shall make, or file, or be interested in more than one bid. However, a person, firm, or corporation that has submitted a subproposal to a bidder, or that has quoted prices of materials to a bidder, is not thereby disqualified from submitting a sub-proposal or quoting prices to other bidders or from submitting a prime proposal.
31. Contractor's State License Board. Contractors and Subcontractors are required by law to be licensed and regulated by the California Contractors' License Board.
32. Labor Compliance Program. This project is subject to prevailing wage requirements and bidder and its subcontractors are required to pay all workers employed for the performance of this project no less than the applicable prevailing wage rate for each such worker. If this project is for a public works project over \$25,000 or for a maintenance project over \$15,000, bidder acknowledges that the project is subject to compliance monitoring and enforcement by the California Department of Industrial Relations in accordance with California Labor Code sections 1725.5 and 1770 *et seq.*
34. Iran Contracting Act Certification/Compliance with Economic Sanctions Certification. Contractors shall submit the Iran Contracting Act Certification and the Compliance with Economic Sanctions Certification with their Bid. Bids submitted without these certifications shall be deemed non-responsive and will not be considered.
35. Additive and Deductive Items: Method of Determining Lowest Bid. Pursuant to Public Contract Code §20103.8, if the bid solicitation includes additive and/or deductive items, the checked [X] method shall be used to determine the lowest bid:

 X (a) The lowest bid shall be the lowest bid price on the base contract without consideration of the prices on the additive or deductive items.

 (b) The lowest bid shall be the lowest total of the bid prices on the base contract and those additive or deductive items that were specifically identified in the bid solicitation or Bid Proposal Form as being used for the purpose of determining the lowest bid price.

 (c) The lowest bid shall be the lowest total of the bid prices on the base contract and those additive or deductive items taken in order from a specifically identified list of those items that, when in the solicitation, and added to, or subtracted from, the base contract, are

less than, or equal to, a funding amount publicly disclosed by the District before the first bid is opened.

_____ (d) The lowest bid shall be determined in a manner that prevents any information that would identify any of the bidders or the proposed Subcontractors or suppliers from being revealed to the public entity before the ranking of all bidders from lowest to highest has been determined.

If no method is checked, sub-paragraph (a) shall be used to determine the lowest bid.

Notwithstanding the method used by the District to determine the lowest responsible bidder, the District retains the right to add to or deduct from the Contract any of the items included in the bid solicitation.

36. COVID-19 Protocol. By entering into the Contract with the District, the Contractor, in performing services under the Contract, agrees to strictly, and without exception, follow all local, state and federal guidelines and protocols regarding COVID, including all District policies and procedures.
37. Bid Protest. Any bid protest must be in writing and received by the District Office before 5:00 p.m. no later than three (3) working days following bid opening and shall comply with the following requirements:
 - a. The bid protest must contain a complete statement of the basis for the protest and all supporting documentation.
 - b. The party filing the protest must have actually submitted a bid for the Project. A Subcontractor of a bidder submitting a bid for the Project may not submit a bid protest. A bidder may not rely on the bid protest submitted by another bidder, but must timely pursue its own protest.
 - c. The protest must refer to the specific portion or portions of the Contract Documents upon which the protest is based.
 - d. The protest must include the name, address and telephone number of the person representing the protesting bidder.
 - e. The bidder filing the protest must concurrently transmit a copy of the bid protest and all supporting documentation to all other bidders with a direct financial interest which may be affected by the outcome of the protest, including all other bidders who appear to have a reasonable prospect of receiving an award depending upon the outcome of the protest.
 - f. The bidder whose bid has been protested may submit a written response to the bid protest. Such response shall be submitted to the District before 5 p.m. no later than two (2) working days after the deadline for submission of the bid protest or receipt of

the bid protest, whichever is sooner, and shall include all supporting documentation. Such response shall also be transmitted concurrently to the protesting bidder and to all other bidders who appear to have a reasonable prospect of receiving an award depending upon the outcome of the protest.

- g. The procedure and time limits set forth in this section are mandatory and are the bidder's sole and exclusive remedy in the event of bid protest. The bidder's failure to comply with these procedures shall constitute a waiver of any right to further pursue the bid protest, including filing a Government Code claim or legal proceedings.
- h. If the District determines that a protest is frivolous, the protesting bidder may be determined to be non-responsible and that bidder may be determined to be ineligible for future contract awards by the District.
- i. A "working day" for purposes of this section means a weekday during which the District's office is open and conducting business, regardless of whether or not school is in session.

BID PROPOSAL FORM

Governing Board
Napa Valley College District

Dear Members of the Governing Board:

The undersigned, doing business under the name of _____, having carefully examined the location of the proposed work, the local conditions of the place where the work is to be done, the Notice Inviting Bids, the General Conditions, the Instructions to Bidders, the Plans and Specifications, and all other Contract Documents for the proposed Napa Valley College Wine Education Center Project ("Project"), and having accurately completed the Bidder's Questionnaire, proposes to perform all work and activities in accordance with the Contract Documents, including all of its component parts, and to furnish all required labor, materials, equipment, transportation and services required for the construction of the Project in strict conformity with the Contract Documents, including the Plans and Specifications, as follows:

BASE BID:

For the sum of

_____ Dollars (\$ _____).

ADDITIVE/DEDUCTIVE ALTERNATE *[if applicable]*:

Additive/Deductive Alternate #1 _____
Add/Subtract _____ Dollars (\$ _____)

Additive/Deductive Alternate #2 _____
Add/Subtract _____ Dollars (\$ _____)

Additive/Deductive Alternate #3 _____
Add/Subtract _____ Dollars (\$ _____)

The undersigned has checked carefully all the above figures and understands that the District is not responsible for any errors or omissions on the part of the undersigned in making this bid.

Enclosed find certified or cashier's check no. _____ of the _____ Bank for _____ Dollars (\$ _____) or Bidder's Bond of the _____ surety company in an amount of not less than ten percent (10%) of the entire bid. The undersigned further agrees, on the acceptance of this proposal, to execute the Contract and provide the required bonds and insurance and that in case of default in executing these documents within the time fixed by the

Contract Documents, the proceeds of the check or bond accompanying this bid shall be forfeited and shall become the property of the District.

Contractor agrees to commence the work within the time specified in the Notice to Proceed. It is understood that this bid is based upon completing the work within the number of calendar days specified in the Contract Documents.

ADDENDA:

Receipt of the following addenda is hereby acknowledged:

Addendum # _____	Dated: _____	Addendum # _____	Dated: _____
Addendum # _____	Dated: _____	Addendum # _____	Dated: _____
Addendum # _____	Dated: _____	Addendum # _____	Dated: _____

Respectfully submitted,

Company: _____

Address: _____

By: _____
(Please Print Or Type)

Signature: _____

Title: _____

Date: _____

Telephone: _____

Contractor's License No: _____ Expiration Date _____

DIR Registration No: _____

- Required Attachments:
- Subcontractor List Form
 - Non-Collusion Declaration
 - Bid Bond (or Cashier's or Certified Check)
 - Bidders' Questionnaire
 - Workers' Compensation Certificate
 - Iran Contracting Act Certification
 - Compliance with Economic Sanctions Certification

WORKERS' COMPENSATION CERTIFICATE

Labor Code §3700 in relevant part provides:

"Every employer except the State shall secure the payment of compensation in one or more of the following ways:

- (a) By being insured against liability to pay compensation in one or more insurers duly authorized to write compensation insurance in this State.
- (b) By securing from the Director of Industrial Relations a certificate of consent to self-insure, which may be given upon furnishing proof satisfactory to the Director of Industrial Relations of ability to self-insure and to pay any compensation that may become due to his employees."

I am aware of the provisions of §3700 of the Labor Code which require every employer to be insured against liability for workers' compensation or to undertake self-insurance in accordance with the provisions of that Code, and I will comply with such provisions before commencing the performance of the work of this Contract and will require all Subcontractors to do the same.

Contractor

By: _____

In accordance with Article 5 (commencing at §1860), Chapter 1, Part 7, Division 2 of the Labor Code, the above certificate must be signed and filed with the awarding body prior to performing any work under this Contract.

NON-COLLUSION DECLARATION

To be executed by the bidder and submitted with the bid.

_____, declares that he or she is _____ of _____, the party making the foregoing bid, and affirms that the bid is not made in the interest of, or on behalf of, any undisclosed person, partnership, company, association, organization, or corporation; that the bid is genuine and not collusive or sham; that the bidder has not directly or indirectly induced or solicited any other bidder to put in a false or sham bid, and has not directly or indirectly colluded, conspired, connived, or agreed with any bidder or anyone else to put in a sham bid, or that anyone shall refrain from bidding; that the bidder has not in any manner, directly or indirectly, sought by agreement, communication, or conference with anyone to fix the bid price of the bidder or any other bidder, or to fix any overhead, profit, or cost element of the bid price, or of that of any other bidder, or to secure any advantage against the public body awarding the contract of anyone interested in the proposed contract; that all statements contained in the bid are true and correct; and, further, that the bidder has not, directly or indirectly, submitted his or her bid price or any breakdown thereof, or the contents thereof, or divulged information or data relative thereto, or paid, and will not pay, any fee to any corporation, partnership, company association, organization, bid depository, or to any member or agent thereof to effectuate a collusive or sham bid.

I declare under penalty of perjury under the laws of the State of California that the foregoing is true and correct.

Date: _____

Signature

IRAN CONTRACTING ACT CERTIFICATION
(Public Contract Code Sections 2202-2208)

As required by California Public Contract Code Section 2204, the Contractor certifies subject to penalty for perjury that the option checked below relating to the Contractor’s status in regard to the Iran Contracting Act of 2010 (Public Contract Code Section 2200 et seq.) is true and correct:

- € The Contractor is not:
 - identified on the current list of persons and entities engaging in investment activities in Iran prepared by the California Department of General Services in accordance with subdivision (b) of Public Contract Code Section 2203; or
 - a financial institution that extends, for 45 days or more, credit in the amount of \$20,000,000 or more to any other person or entity identified on the current list of persons and entities engaging in investment activities in Iran prepared by the California Department of General Services in accordance with subdivision (b) of Public Contract Code Section 2203, if that person or entity uses or will use the credit to provide goods or services in the energy sector in Iran.

- € The District has exempted the Contractor from the requirements of the Iran Contracting Act of 2010 after making a public finding that, absent the exemption, the District will be unable to obtain the goods and/or services to be provided pursuant to the Contract.

- € The amount of the Contract payable to the Contractor for the Project does not exceed \$1,000,000.

I certify (or declare) under penalty of perjury under the laws of the State of California that the foregoing is true and correct.

Signature	Date
-----------	------

Name	Title
------	-------

Name of Contractor

COMPLIANCE WITH ECONOMIC SANCTIONS CERTIFICATION

As required by Executive Order N-6-22, issued by Governor Gavin Newsom on March 4, 2022 (“EO”), the Contractor certifies compliance with the economic sanctions imposed in response to Russia’s actions in Ukraine, including with respect to, but not limited to, the federal executive orders identified in the EO and the sanctions identified on the U.S. Department of the Treasury website (<https://home.treasury.gov/policy-issues/financial-sanctions/sanctions-programs-and-country-information/ukraine-russia-related-sanctions>). Contractor understands that failure to comply may result in the termination of this Agreement.

If this Agreement is valued at \$5 million or more, Contractor understands and agrees that within 45 days of receipt of the Notice to Proceed, it must report in writing to the District on steps it has taken to comply with the EO and with Federal Executive Order 14065, including but not limited to, desisting from making new investments in, or engaging in financial transactions with Russian entities.

I certify (or declare) under penalty of perjury under the laws of the State of California that the foregoing is true and correct.

Signature _____ Date _____

Name _____ Title _____

Name of Contractor _____

BID BOND

We, the Contractor, _____ as principal (“Principal”), and _____, as surety (“Surety”), are firmly bound unto the Napa Valley College District (“District”) in the penal sum of ten percent (10%) of the total amount of the bid of the Principal submitted to the District for the work described below for the payment of which sum in lawful money of the United States, we bind ourselves, our heirs, executors, administrators, successors and assigns, jointly and severally, firmly by this agreement.

Whereas, the Principal has submitted the accompanying bid (“Bid”) dated _____, for the following project (“Project”): Napa Valley College Wine Education Center.

Now, therefore, if the Principal does not withdraw its Bid within the period specified, and if the Principal is awarded the Contract and within the period specified fails to enter into a written contract with District, in accordance with the Bid as accepted, or fails to provide the proof of required insurance, the performance bond and/or the payment bond by an admitted surety within the time required, or in the event of unauthorized withdrawal of the Bid, if the Principal pays the District the difference between the amount specified in the Bid and the amount for which District may otherwise procure the required work and/or supplies, if the latter amount is in excess of the former, together with all related costs incurred by District, then the above obligation shall be void and of no effect. Otherwise, the Principal and Surety shall pay to the District the penal sum described above as liquidated damages.

Surety, for value received, hereby agrees that no change, extension of time, alteration or addition to the term of the Contract or the call for bids, or to the work to be performed thereunder, or the Specifications accompanying the same, shall in any way affect its obligation under this bond, and it does hereby waive notice of any such change, extension of time, alteration or addition.

In witness whereof the above-bound parties have executed this instrument under their several seals this _____ day of _____, 20____, the name and corporate seal of each corporate Party being hereunder affixed and these presents duly signed by its undersigned representative, pursuant to the authority of its governing body.

(Corporate Seal)

Principal/Contractor

By _____

Title: _____

(Corporate Seal)

Surety

Attach Attorney-In-Fact Certificate

By _____

Title

To be signed by Principal and Surety and Acknowledgment and Notary Seal to be attached.

BIDDER'S QUESTIONNAIRE

For the

Napa Valley College Wine Education Center Project

TO THE BIDDER:

In making its award, the Governing Board will take into consideration the Bidder's experience, financial responsibility and capability. The following questionnaire is a part of the bid. Any bid received without this completed questionnaire may be rejected as nonresponsive. The Board will use, but will not be limited to, the information provided herein for evaluating the qualifications and responsibility of the bidder and the bidder's organization to carry out satisfactorily the terms of the Contract Document. The questionnaire must be filled out accurately and completely and submitted with the bid. Any errors, omissions or misrepresentation of information may be considered as a basis for the rejection of the bid and may be grounds for the termination of any contract executed as a result of the bid.

A. Description of Bidder's Organization

1. Firm Name _____

2. Address _____

3. Telephone Number _____

4. Type of Organization

a. Corporation? Yes ____ No ____

If yes, list the officers and positions, and the State in which incorporated.

If the Bidder corporation is a subsidiary, give name and address of parent corporation.

b. Partnership? Yes ____ No ____

If yes, list partner names and addresses

General Partners:

Limited Partners:

c. Individual Proprietorship? Yes ____ No ____

If yes, list name and address of proprietor:

B. Nature of Operations

1. How long have you been engaged in the contracting business under your present business name? _____

2. How many years of experience does your business have in construction work similar to that called for under this bid? _____

3. Have you now contracts, or have you ever contracted, to provide construction for any school district, community college district or county office of education in the State of California?
Yes ____ No ____

a. If "yes," on a separate attached sheet, provide the following information for all construction projects you have had with school districts, community college districts and county offices of education during the last four (4) years:

- 1. Year contract awarded
- 2. Type of work

3. Contract completion time called for/actual completion time
 4. Contract price
 5. For whom performed, including person to call for a reference and telephone number
 6. Location of work
 7. Number of stop notices filed
 8. For each contract, list any lawsuits filed relating to that contract in which you were a defendant or plaintiff
 9. Amount of liquidated damages assessed.
- b. On a separate attached sheet, provide the following information for all construction contracts of a similar nature as called for in this bid that you have had with entities other than school districts, community college districts and county offices of education during the last four (4) years:
1. Year contract awarded
 2. Type of work
 3. Contract completion time called for/actual completion time
 4. Contract price
 5. For whom performed, including person to call for reference and phone number
 6. Location of work
 7. Number of stop notices filed
 8. For each contract list any lawsuits filed relating to that contract in which you were a defendant or plaintiff
 9. Amount of liquidated damages assessed.
- c. For each construction contract that you have failed to complete within the contract time in the last four years please state the reasons for the untimely performance.'

C. Financial and Credit Data

1. If your bid is considered for award, and if requested by the District, will you supply the following data? Yes ____ No ____
 - a. Names and addresses of any banks where you regularly do business.
 - b. The names and addresses of any banks, finance companies, dealers, suppliers, or others where you have notes or loans.
 - c. Give credit references, including at least three trade or industry suppliers with whom you regularly deal.
2. Will you submit on request a balance sheet for the past three (3) years?
Yes ____ No ____

3. Where have you engaged in the construction business, or any other type of business, in the last five years?

<u>Name of Business</u>	<u>Location</u>	<u>Type of Business</u>	<u>Years in Business</u>
-------------------------	-----------------	-------------------------	--------------------------

If any of the business endeavors referred to above are no longer operating, or you are no longer associated with them, please give brief details:

4. The following surety companies may be contacted as references as to the financial responsibility and general reliability of the bidder:

<u>Surety Name</u>	<u>Contact Person</u>	<u>Phone Number</u>
--------------------	-----------------------	---------------------

I certify under penalty of perjury that the foregoing is true and correct. Executed at _____, California, on _____, 20__.

Signature of Bidder _____

Name (*print*) _____

CONTRACT

This Contract ("Contract") is made by and between the Napa Valley College District ("District"), and _____ ("Contractor").

District and Contractor hereby agree as follows:

1. Description of Work

The Contractor agrees to furnish all labor, materials, equipment, tools, supervision, appurtenances, and services, including transportation and utilities, required to perform and satisfactorily complete all work required for the following project ("Project") in full conformance with the Contract Documents: Napa Valley College Wine Education Center.

2. Contract Documents

The Contract Documents consist of the executed Contract and all Addenda, all approved change orders, the completed Bid Form, the required Bonds and the Insurance forms, the Notice Inviting Bids, the Instructions to Bidders, the Notice of Award, the Notice to Proceed, the General Conditions and any supplemental conditions, the Technical Specifications, the Drawings, the completed Bidder's Questionnaire, and.

3. Compensation

As full compensation for the Contractor's complete and satisfactory performance of the work and activities described in the Contract Documents, the District agrees to pay Contractor, and Contractor agrees to accept the sum of _____ Dollars (\$ _____), which shall be paid to the Contractor according to the Contract Documents.

4. Prevailing Wages and Labor Compliance

This Project is subject to prevailing wage requirements and Contractor and its Subcontractors are required to pay all workers employed for the performance of this Contract no less than the applicable prevailing wage rate for each such worker. The project is subject to compliance monitoring and enforcement by the California Department of Industrial Relations. In accordance with SB 854, all bidders, contractors and subcontractors working at the site shall be duly registered with the Department of Industrial Relations at time of bid opening and at all relevant times. Proof of registration shall be provided as to all such contractors prior to the commencement of any work.

5. Time for Completion

The starting date of the Contract shall be the day listed by the District in the Notice to Proceed and the Contractor shall fully complete all the work before the expiration of 365 calendar days from the starting date. Time is of the essence in the performance of this Contract.

6. Liquidated Damages

Liquidated damages for the Contractor's failure to complete the Contract within the time fixed for completion are established in the amount of \$1,000.00 per calendar day.

IN WITNESS WHEREOF, the parties agree to the terms of this Contract on the day and year written below.

Napa Valley College
District

Contractor

By: _____
Individual Signature

Contractor License No.
and Expiration Date

By: _____

Individual Signature

Title

Date

For: _____
Corporation or Partnership

If Corporation, Affix Seal.

GENERAL CONDITIONS

TABLE OF CONTENTS

1. Definitions 4

2. Architect 5

3. Contract Documents 6

4. Intent of Drawings and Specifications 7

5. Trade Divisions 7

6. Master Mandatory Provisions 8

7. Contractor 8

8. Responsibility of General Contractor 9

9. Subcontractors 10

10. Performance and Payment Bonds 10

11. Insurance 11

12. Codes and Regulations 14

13. Permits and Taxes 14

14. Patents and Royalties 15

15. Safety and Fire Prevention 15

16. Hazardous Materials 16

17. Temporary Facilities 17

18. Signs 18

19. Time 18

20. Construction Schedule 18

21. Delays and Time Extensions 19

22. Liquidated Damages20

23. District’s Right To Stop Work; Terminate The Contract21

24. Assignment of Contract22

25. Coordination With Other Contracts22

26. Submittals: Shop Drawings, Cuts and Samples23

27. Payments24

28. Modifications of Contract26

29. Indemnity29

30. Warranty of Title29

31. Use of Completed Parts of The Work Before Acceptance29

32. Guarantee and Warranty30

33. Protection of Work and Property30

34. Use of Roadways and Walkways31

35. Materials.....31

36. Substitutions32

37. Testing32

38. Inspection33

39. Cleanup33

40. Construction Waste Management Requirements34

41. Instructions and Manuals37

42. As-Built Drawings38

43. Substitution of Securities38

44. No Discrimination39

45. Labor Standards39

46. General Rate of Per Diem Wages40

47. Record Keeping40

48. Project Completion42

49. Trenching or Other Excavations42

50. Resolution of Construction Claims44

51. Labor Compliance Program.....46

52. Drug-Free Workplace Certification.....46

53. Provisions Required By Law Deemed Inserted.....47

54. General Provisions47

1. DEFINITIONS

Addendum: A written change or revision to the Contract Documents issued to the prospective bidders prior to the time of receiving bids.

Alternate: The sum to be added to or deducted from the base Bid if the change in scope of work as described in Alternates is accepted by the District.

Approved: Approved by the District or the District's authorized representative unless otherwise indicated in the Contract Documents.

Architect: The person or firm holding a valid license to practice architecture or engineering which has been designated (if any designated) to provide architectural or engineering design services on this Project. When Architect is referred to within the Contract Documents and no architect or engineer has in fact been designated, then the matter shall be referred to the District Superintendent or designee.

As Directed: As directed by the District or its Architect, unless otherwise indicated in the Contract Documents.

As Selected: As selected by the District or its Architect, unless otherwise indicated in the Contract Documents.

Bid: The properly completed and signed proposal to perform the construction work for the Project as described in the Contract Documents.

Construction Manager: The individual or entity named as such by the District. If no Construction Manager is designated for the Project, all references to the Construction Manager in these Contract Documents shall mean the District and/or its designee.

Contract: The legally binding agreement between the District and the Contractor wherein the Contractor agrees to furnish the labor, materials, equipment, and appurtenances required to perform the work described in the Contract Documents and the District agrees to pay the Contractor for such work.

Contract Documents: The Contract Documents are described in the Contract for this Project.

Contractor: The person or entity holding a valid license in the State of California required for performing this Project and who has contracted with the District to perform the construction work described in the Contract Documents. The term Contractor shall be construed to mean all of the officers, employees, Subcontractors, suppliers, or other persons engaged by the Contractor for the work of this Project.

District and/or Owner: The District, its Governing Board, authorized officers and employees, and authorized representatives.

DSA: The State of California Division of the State Architect which has the authority to review, approve and inspect the design, alteration and construction of school buildings.

Final Completion: Final Completion is achieved when the Contractor has fully completed all Contract Document requirements, including, but not limited to, all final punch list items, to the District's satisfaction.

Inspector: The person engaged by the District to conduct the inspections required by the Education Code and Title 24.

Furnish: Purchase and deliver to the site of installation.

Governing Board: The Governing Board of the District.

Indicated or As Shown: Shown on drawings and/or as specified.

Install: Fix in place, for materials; and fix in place and connect, for equipment.

Modification: An authorized change to the Contract Documents which may or may not include a change in contract price and/or time.

Project: The total construction work and activities described in these Contract Documents.

Secure: Obtain.

Subcontractor: A person, firm, or corporation, duly licensed by the State of California, who has a contract with the Contractor to furnish labor, materials and equipment, and/or to install materials and equipment for work in this Contract.

2. ARCHITECT

The Architect is responsible for the overall design of the Project. The working drawings, technical Specifications, sketches and other information necessary to define the work covered by these Contract Documents have been prepared by the Architect. The Architect shall visit, inspect and observe the construction to determine general compliance with the Contract Documents, and interpret the drawings and Specifications consistent with their intent. The Architect shall evaluate the samples and other submittals required in the technical Specifications, and maintain an up-to-date log of all such items processed. The Architect will consult with the District, Contractor, and any state, county or city agency having jurisdiction over the work whenever necessary to further the best interests of the Project.

3. CONTRACT DOCUMENTS

a. Contents and Precedence

The Contract Documents consist of the executed Contract and all Addenda, all approved change orders, the completed Bid Form, the required Bonds and the Insurance forms, the Notice Inviting Bids, the Instructions to Bidders, the Notice of Award, the Notice to Proceed, the General Conditions, any supplemental Conditions, the Technical Specifications, the Drawings and the completed Bidder's Questionnaire. The Contract Documents are complementary and anything required by one shall be as binding as if required by all. In case of conflicts within the Contract Documents, the order of precedence of interpretation shall be as listed above, with the executed Contract and any change order thereto having priority, and subsequent Addenda having priority over prior Addenda only to the extent modified by the subsequent Addenda. In case of conflict within the drawings, larger scale drawings shall govern smaller scale drawings, and written dimensions shall govern over scaled dimensions.

b. Ambiguities, Errors, and Inconsistencies

If, in the opinion of the Contractor, the construction details indicated on the drawings or otherwise specified are in conflict with accepted industry standards for quality construction and therefore might interfere with its full guarantee of the work involved, the Contractor shall promptly bring this information to the attention of the Architect for appropriate action before submittal of the bid. Contractor's failure to request clarification or interpretation of an apparent ambiguity, error or inconsistency waives that Contractor's right to thereafter claim any entitlement to additional compensation based upon an ambiguity, inconsistency, or error, which should have been discovered by a reasonably prudent Contractor, subject to the limitations of Public Contract Code §1104. During the Project, should any discrepancy appear or any misunderstanding arise as to the import of anything contained in the Contract Documents, the matter shall be promptly referred to the Architect, who will issue instructions or corrections.

c. Lines and Planes

All lines and planes appearing on Contract drawings to be horizontal or vertical and not explicitly indicated otherwise shall be constructed true and plumb. All lines and planes appearing on Contract drawings to intersect at right angles and not explicitly indicated otherwise shall be constructed at true right angles. Where details are indicated covering specific conditions, such details also apply to all similar conditions not specifically indicated.

d. Standards

The specification standards of the various sections of the Specifications shall be the procedural, performance, and material standards of the applicable association publications identified and shall be the required level of installation, materials, workmanship, and performance for the applicable work. Except where a specific date of issue is mentioned

hereinafter, references to specification standards shall mean the edition, including amendments and supplements, in effect on the date of the Notice Inviting Bids. Where no standard is identified and a manufacturer is specified, the manufacturer's specifications are the standards. All standards shall be subordinate to the requirements of the applicable codes and regulations.

e. Reference to the Singular

Wherever in the Specifications an article, device or piece of equipment is referred to in the singular number, such reference shall include as many such items as are shown on drawings or required to complete the installation.

4. INTENT OF DRAWINGS AND SPECIFICATIONS

- a. Drawings and Specifications are to be read as an integrated document. The Contractor shall promptly report to the Architect any ambiguities, discrepancies, or errors which come to the Contractor's attention.
- b. Figured dimensions shall be followed in preference to scaled dimensions, and the Contractor shall make all additional measurements necessary for the work and shall be responsible for their accuracy. Before ordering any material or doing any work, the Contractor shall verify all measurements at the Project site and shall be responsible for the correctness of same.
- c. It is the intent of the drawings and Specifications to show and describe complete installations. Items shown but not specified, or specified but not shown, shall be included unless specifically omitted.
 - 1) The Specifications shall be deemed to include and require everything necessary and reasonably incidental to the completion of all work described and indicated on the drawings, whether particularly mentioned or shown, or not.

5. TRADE DIVISIONS

Segregation of the Specifications into the designated trade divisions is only for the purpose of facilitating descriptions and shall not be considered as limiting the work of any subcontract or trade. Subject to other necessary provisions set forth in the Specifications, the terms and conditions of such limitations or inclusions shall lie solely between the Contractor and its Subcontractors. "Scope" as indicated in each section of the Specifications shall serve only as a general guide to what is included in that section. Neither the stated description nor the division of the plans and Specifications to various sections, which is done solely for convenience, shall be deemed to limit the work required, divide or indicate it by labor jurisdiction or trade practice, or set up any bidding barriers to the various sub-contractors or suppliers.

- a. The Contractor shall be responsible for the proper execution of all work required by the Contract Documents and for allocating such portions as the Contractor sees fit to the various Subcontractors, subject to applicable law. The Contractor is cautioned that the various

individual sections may not contain all work that the Contractor may wish to allocate to a particular Subcontractor or everything bearing on the work of a particular trade, some of which may appear in other portions of the plans or Specifications.

- b. If the Contractor elects to enter into any subcontract for any section of the work the Contractor assumes all responsibility for ascertaining that the Subcontractor for the work is competent, licensed, solvent, thoroughly acquainted with all conditions and legal requirements of the work, has included all materials and appurtenances in connection therewith in the subcontract, and has performed its work in strict compliance with the Contract Documents.
- c. It shall be the responsibility of the Contractor to notify each prospective Subcontractor at the time of request for bids of all portions of the Contract Documents, including the General Conditions, Supplementary Conditions and any parts of sections of Specifications or plans that the Contractor intends to include as part of the subcontract.

6. MASTER MANDATORY PROVISIONS

- a. Any material, item, or piece of equipment mentioned, listed or indicated without definition of quality, shall be consistent with the quality of adjacent or related materials, items, or pieces of equipment on the Project.
- b. Any method of installation, finish, or workmanship of an operation called for, without definition of standard of workmanship, shall be followed or performed and finished in accordance with best practices and consistent with adjacent or related installations on the Project.
- c. Any necessary material, item, piece of equipment or operation not called for but reasonably implied as necessary for proper completion of the work shall be furnished, installed or performed and finished; and shall be consistent with adjacent or related materials, items, or pieces of equipment on the Project, and in accordance with best practices.
- d. Names or numbered products are to be used according to the manufacturers' directions or recommendations unless otherwise specified.

7. CONTRACTOR

- a. The Contractor shall perform all the work and activities required by the Contract Documents and furnish all labor, materials, equipment, tools and appurtenances necessary to perform the work and complete it to the District's satisfaction within the time specified. The Contractor shall at all times perform the work of this Contract in a competent and workmanlike manner and, if not specifically stated, accomplish the work according to the best standards of construction practice. The Contractor in no way is relieved of any responsibility by the activities of the architect, engineer, inspector or DSA in the performance of such duties.

- b. The Contractor shall employ a full-time competent superintendent and necessary assistants who shall have complete authority to act for the Contractor on all matters pertaining to the work. The superintendent shall be satisfactory to the District and, if not satisfactory, shall be replaced by the Contractor with one that is acceptable. Also, the superintendent shall not be changed without the written consent of the District unless the superintendent ceases to be employed by the Contractor.
- c. Contractor shall make the layout of lines and elevations and shall be responsible for the accuracy of both the Contractor's and the Subcontractors' work resulting therefrom. All dimensions affecting proper fabrication and installation of all Contract work must be verified by the Contractor prior to fabrication and installation by taking field measurements of the true conditions. The Contractor shall take, and assist Subcontractors in taking, all field dimensions required in performance of the work, and shall verify all dimensions and conditions on the site. If there are any discrepancies between dimensions in drawings and existing conditions which will affect the work, the Contractor shall promptly bring such discrepancies to the attention of the Architect for adjustment before proceeding with the work. Contractor shall be responsible for the proper fitting of all work and for the coordination of all trades, Subcontractors and persons engaged upon this Contract.
- d. Contractor shall do all cutting, fitting, or patching of Contractor's work that may be required to make its several parts come together properly and fit it to receive or be received by work of other contractors as shown, or reasonably implied by, the drawings and Specifications for the completed work. Any cost incurred by the District due to defective or ill-timed work shall be borne by the Contractor.

8. RESPONSIBILITY OF CONTRACTOR

- a. Contractor shall be held strictly responsible for the proper performance of all work covered by the Contract Documents, including all work performed by Subcontractors. All work performed under this Contract shall comply in every respect to the rules and regulations of all agencies having jurisdiction over the Project or any part thereof.
- b. Contractor shall submit Verified Reports as defined in §§4-336 and 4-343 (c), Group 1, Chapter 4, Part I, Title 24, California Code of Regulations ("CCR"). The duties of the Contractor are as defined in §4-343, Group 1, Chapter 4, Part I, Title 24, of the CCR. Contractor shall keep and make available a copy of Title 24 of the CCR at the job site at all times.
- c. Where, because of short supply, any item of fabricated materials and/or equipment, indicated on drawings or specified is unobtainable and it becomes necessary, with the consent of the Architect, to substitute equivalent items differing in details or design, the Contractor shall promptly submit complete drawings and details indicating the necessary modifications of the work. This provision shall be governed by the terms of the General Conditions regarding Submittals: Shop Drawings, Cuts and Samples.

- d. With respect to work performed at and near a school site, Contractor shall at all times take all appropriate measures to ensure the security and safety of students and staff, including, but not limited to, ensuring that all of Contractor’s employees, Subcontractors, and suppliers entering school property strictly adhere to all applicable District policies and procedures, e.g., sign-in requirements, visitor badges, and access limitations.

9. SUBCONTRACTORS

- a. Nothing contained in the Contract Documents shall create any contractual relationship between any Subcontractor and the District. The District shall be deemed to be the third party beneficiary of the contract between the Contractor and each Subcontractor. If the Contractor does not specify a Subcontractor for any portion of the work to be performed under this Contract, as required by law, Contractor shall perform that portion of the work with its own forces. The Contractor shall not substitute any other person or firm as a Subcontractor for those listed in the bid submitted by the Contractor, without the written approval of the District and in conformance with the requirements of the Public Contract Code. The District reserves the right of approval of all Subcontractors proposed for use on this Project, and to this end, may require financial, performance, and such additional information as is needed to secure this approval. If a Subcontractor is not approved, the Contractor shall promptly submit another firm of the same trade for approval.
- b. The Contractor shall insert appropriate provisions in all subcontracts pertaining to work on this Project requiring the Subcontractors to be bound by all applicable terms of the Contract Documents. The Contractor shall be as fully responsible for the acts and omissions of the Subcontractors, and of persons either directly or indirectly employed by them, as the Contractor is for the acts and omissions of persons directly employed by the Contractor.

10. PERFORMANCE AND PAYMENT BONDS

- a. As directed in the Notice of Award, the Contractor shall file with the District the following bonds, using the bond forms provided with these Contract Documents:
 - 1) A corporate surety bond, in a sum not less than 100 percent of the amount of the Contract, to guarantee the faithful performance of the Contract.
 - 2) A corporate surety bond, in a sum not less than 100 percent of the amount of the Contract, to guarantee the payment of wages for services engaged and of bills contracted for materials, supplies, and equipment used in the performance of the Contract.
- b. Corporate sureties on these bonds and on bonds accompanying bids must be admitted sureties as defined by law, legally authorized to engage in the business of furnishing surety bonds in the State of California. All sureties and bond forms must be satisfactory to the District. Failure to submit the required bonds within the time specified by the Notice of Award, using the forms provided by the District, may result in cancellation of the award of Contract and forfeiture of the Bid Bond.

- c. The amount of the Contract, as used to determine the amounts of the bonds, shall be the total amount fixed in the Contractor's proposal for the performance of the required work.
- d. During the period covered by the Contract, if any of the sureties upon the bonds shall become insolvent or unable, in the opinion of the District, to pay promptly the amount of such bonds to the extent to which surety might be liable, the Contractor, within thirty (30) days after notice given by the District to the Contractor, shall provide supplemental bonds or otherwise substitute another and sufficient surety approved by the District in place of the surety becoming insolvent or unable to pay. If the Contractor fails within such thirty (30) day period to substitute another and sufficient surety, the Contractor shall, if the District so elects, be deemed to be in default in the performance of its obligations hereunder and upon the bid bond, and the District, in addition to any and all other remedies, may terminate the Contract or bring any proper suit or other proceedings against the Contractor and the sureties or any of them, or may deduct from any monies then due or which thereafter may become due to the Contractor under the Contract, the amount for which the surety, insolvent or unable to pay, shall have been liable on the bonds, and the monies so deducted shall be held by the District as collateral security for the performance of the conditions of the bonds.

11. INSURANCE

- a. Contractor shall obtain insurance from a company or companies acceptable to District. All required insurance must be written by an admitted company licensed to do business in the State of California at the time the policy is issued. All required insurance shall be equal to or exceed an A VIII rating as listed in Best's Insurance Guide's latest edition. Required documentation of such insurance shall be furnished to the District at the time Contractor returns the executed Contract. Contractor shall not commence work nor shall it allow its employees or Subcontractors or anyone to commence work until all insurance required hereunder has been submitted and approved by the District and a notice to proceed has been issued.
- b. Contractor shall take out and maintain at all times during the life of this Contract, up to the date of acceptance of the work by the District, the following policies of insurance:
 - 1) General Liability Insurance: Personal injury and replacement value property damage insurance for all activities of the Contractor and its Subcontractors arising out of or in connection with this Contract, written on a comprehensive general liability form including contractor's protected coverage, blanket contractual, completed operations, vehicle coverage and employer's non-ownership liability coverage, in an amount no less than either:
 - a. \$2,000,000.00 combined single limit personal injury and property damage for each occurrence and \$4,000,000.00 annual aggregate or
 - b. \$4,000,000.00 annual combined single limit.

2) Builders Risk Insurance:

 Contractor is not required to procure and maintain builders' risk insurance (all-risk coverage).

 X Contractor shall procure and maintain builders' risk insurance (all-risk coverage) on a one hundred percent completed value basis on the insurable portion of the project for the benefit of the District, and the Contractor and subcontractor as their interest may appear.

3) Automobile Liability Insurance: Covering bodily injury and property damage in an amount no less than \$1,000,000.00 combined single limit for each occurrence. Such insurance shall include coverage for owned, hired, and non-owned vehicles and be included on the umbrella/excess policy.

- c. The certificate(s) for both the General Liability Policy(ies) and the Automobile Liability Policy specified above must state that the insurance is under an occurrence based, and not claims made, policy(ies) and shall be endorsed with the following specific language:

“The Napa Valley Community College District is named as additional insured for all liability arising out of the operations by or on behalf of the named insured, and this policy protects the additional insured, its officers, agents and employees against liability for bodily injuries, deaths or property damage or destruction arising in any respect directly or indirectly in the performance of the Contract.”

- d. The certificate(s) for both the General Liability Policy and the Automobile Liability Policy, as well the Builders' Risk Policy if required above, shall be endorsed with the following specific language:

- 1) The inclusion of more than one insured shall not operate to impair the rights of one insured against another insured and the coverages afforded shall apply as though separate policies have been issued to each insured.
- 2) The insurance provided herein is primary and no insurance held or owned by the District shall be called upon to contribute to a loss.
- 3) Coverage provided by this policy shall not be reduced or canceled without thirty (30) days written notice given to the Owner by certified mail.
- 4) This policy does not exclude explosion, collapse, underground excavation hazard, or removal of lateral support.
- 5) The certificates must state that the insurance is under an occurrence based, and not a claims-made, or "modified occurrence," policy (policies).

- e. Within ten (10) days following issuance of the Notice of Award of the Contract, the following documentation of insurance shall be submitted to District for approval prior to issuance of the Notice to Proceed: Certificates of insurance showing the limits of insurance provided, certified copies of all policies, and signed copies of the specified endorsements for each policy. At the time of making application for an extension of time, the Contractor shall submit evidence that the insurance policies will be in effect during the requested additional period of time.
- f. If the Contractor fails to maintain such insurance, the District may take out such insurance to cover any damages of the above mentioned classes for which the District might be held liable on account of the Contractor's failure to pay such damages, and deduct and retain the amount of the premiums from any sums due the Contractor under the Contract.
- g. Workers' Compensation Insurance:
 - 1) Within ten (10) calendar days following issuance of the Notice of Award of the Contract, the Contractor shall furnish to the District satisfactory proof that the Contractor and all Subcontractors it intends to employ have procured, for the period covered by the Contract, full Workers' Compensation insurance and employer's liability with limits of at least \$1,000,000 with an insurance carrier satisfactory to the District for all persons whom the Contractor may employ in carrying out the work contemplated under this Contract in accordance with the Workers' Compensation Insurance and Safety Act, approved May 26, 1913, and all acts amendatory or supplemental thereto (the "Act"). Such insurance shall be maintained in full force and effect during the period covered by the Contract. In the event the Contractor is self-insured, Contractor shall furnish a Certificate of Permission to Self-Insure, signed by the Department of Industrial Relations Administration of Self-Insurance, Sacramento, California.
 - 2) If the Contractor fails to maintain such insurance, the District may take out worker's compensation insurance to cover any compensation which the District might be liable to pay under the provisions of the Act, by reason of any employee of the Contractor being injured or killed, and deduct and retain the amount of the premiums for such insurance from any sums due the Contractor under the Contract, or otherwise recover that amount from the Contractor or the Surety.
 - 3) If an injury occurs to any employee of the Contractor for which the employee, or the employee's dependents in the event of the employee's death, is entitled to compensation under the provisions of the Act, or for which compensation is claimed from the District, the District may retain from the sums due the Contractor under this Contract an amount sufficient to cover such compensation, as fixed by the Act, until such compensation is paid, or until it is determined that no compensation is due, and if the District is compelled to pay such compensation, it will deduct and retain from such sums the amount so paid, or otherwise recover this sum from the Contractor or its Surety.

- 4) The policies represented by the certificates shall be endorsed with a Waiver of Subrogation and must contain the provision (and the certificates must so state) that the insurance cannot be canceled until thirty (30) days after written notice of intended cancellation has been given to the District by certified mail.

12. CODES AND REGULATIONS

- a. The Contractor shall be knowledgeable regarding and shall comply with applicable portions of California Code of Regulations Title 24, the applicable Building Code, and all other codes, ordinances, regulations or orders of properly constituted authority having jurisdiction over the work of this Project. The Contractor shall examine the Contract Documents for compliance with these codes and regulations and shall promptly notify the Architect of any discrepancies.
- b. All work and materials shall be in full accordance with the latest rules and regulations of the Safety Orders of the Division of Industrial Safety and the applicable State laws and/or regulations. Nothing in the Project plans or Specifications is to be construed to permit work not conforming to the applicable Codes. Buildings and/or all other construction covered by this Contract shall meet all the regulations for access by the physically handicapped as administered by the Division of the State Architect and as may be required by federal or state law.
- c. If the work under this Contract is for the construction of a school building as defined by the Education Code, then the following provisions shall apply to the Contract:
 - 1) All work shall be executed in accordance with the current requirements of the Education Code and California Code of Regulations: Title 24 and Title 19. No deviations from the DSA approved plans and Specifications will be permitted except upon a Change Order or Addenda, signed by the District and Architect and approved by the Division of the State Architect and the State Fire Marshal, if applicable.
 - 2) The Division of the State Architect shall be notified 48 hours in advance of the first pour of concrete.

13. PERMITS AND TAXES

- a. The Contractor shall obtain and pay for all permits, fees and licenses that are required in order to perform the work under this Contract. The District shall pay connection charges and meter costs for new permanent utilities required by these Contract Documents. The Contractor shall notify the District sufficiently in advance to submit requests for service to the appropriate utility companies so as to insure connections or installation of utility services in accordance with the Project schedule.
- b. The Contractor shall pay for all taxes on materials and equipment. The District is exempt from Federal Excise Tax. Contractor shall not pay Federal Excise Tax on any item in this Contract.

14. PATENTS AND ROYALTIES

All fees or claims for patents, royalties or licenses on materials, equipment or processes used in the performance of work on this Project shall be included in the amount of the Bid. The Contractor shall indemnify, defend, and hold harmless the District, its Governing Board, the Architect, and their officers and employees, from all claims or liability, including costs and expenses, which may arise from the use on this Project of any patented or copyrighted materials, equipment, or processes.

15. SAFETY AND FIRE PREVENTION

- a. The Contractor, Subcontractors and all of their agents and employees shall fully comply with all of the provisions and requirements of CAL/OSHA, Title 8, California Code of Regulations and all other safety codes applicable to the Project, including but not limited to, all federal, state, local and District ordinances and protocols relating to COVID-19. The Contractor shall take thorough precautions at all times for the protection of persons and property, and shall be liable for all damages to persons or property, either on or off the site, which occur as a result of Contractor’s prosecution of the work. The Contractor shall obtain permits for, install and maintain in safe condition barricades, walkways, fences, railings, and whatever other safeguards that may be necessary to protect persons and property from damage as a result of the construction under this Contract.
- b. The Contractor, in performing services under this Contract, agrees to strictly, and without exception, follow all local, state and federal guidelines and protocols regarding COVID, including all District policies and procedures.
- c. Contractor is required to ensure Material Safety Data Sheets (“MSDS”) are available in a readily accessible place at the work site for any material requiring a MSDS pursuant to the federal "Hazard Communication" standard or employee "right to know" laws. Contractor is also required to ensure proper labeling on materials brought on the job site such that any person working with the material or within the general area of the material is informed of the hazards of the material and follows proper handling and protection procedures. A copy of the MSDS shall also be promptly submitted directly to the District.
- d. Contractor shall not endanger any work by cutting, excavating, or otherwise altering the work and shall not cut or alter the work of any other contractor except with the written consent of the Architect, nor overload any new or existing structures by the placing or storage of materials, equipment, or other items thereon, and, if necessary, shall provide calculations proving the safety in so doing.
- e. If it is necessary to work at night, or where daylight is obscured, the Contractor shall provide and maintain lighting of an adequate level to properly prosecute the work, to permit the thorough inspection of same, and to ensure the safety to workers and others.
- f. Contractor shall take extraordinary care to prevent fires and keep all flammable materials and oily rags in tightly closed metal containers. Contractor shall exercise particular care

when welding or cutting, and with regard to the disposition of waste materials, the nature and quantity of which might create or increase a fire hazard.

16. HAZARDOUS MATERIALS

Unless otherwise specified, this Contract does not include the removal, handling, or disturbance of any hazardous substances or materials encountered in the new construction or on the Project grounds. If such substances or materials are encountered, work shall cease in that area and the District shall be promptly notified to take appropriate action for removal or otherwise abating the condition in accordance with current regulations applicable to the District.

a. General

- 1) No asbestos, asbestos-containing products or other hazardous materials shall be used in this construction or in any tools, devices, clothing or equipment used to further this construction.
- 2) Asbestos and/or asbestos containing products shall be defined as all items containing but not limited to chrysotile, crocidolite, amosite, anthophyllite, tremo-lite or actinolite.
- 3) Any or all material containing greater than one tenth of one percent (>.1%) asbestos shall be defined as asbestos-containing material.
- 4) Any disputes involving the question of whether or not material contains asbestos shall be settled by electron microscopy; the cost of any such tests shall be paid by the Contractor.
- 5) All work or materials found to contain asbestos or work or material installed with asbestos containing equipment will be immediately rejected and this work shall be removed by the Contractor at no additional cost to the District.

b. Decontamination and Removal of hazardous material from prior work

- 1) Decontamination and removal of work found to contain asbestos or work installed with asbestos containing equipment shall be done only under the supervision of a qualified consultant, knowledgeable in the field of asbestos abatement and accredited by the Environmental Protection Agency (“EPA”).
- 2) The asbestos removal contractor shall be an EPA-accredited contractor qualified in the removal of asbestos subject to the approval of the District.
- 3) The asbestos consultant shall be chosen and approved by the District which shall have sole discretion and final determination in this matter.

- 4) The work will not be accepted until asbestos contamination is reduced to levels deemed acceptable by the asbestos consultant.

c. Hold Harmless

- 1) Interface of work under this Contract with work containing asbestos shall be executed by the Contractor at Contractor's risk and at Contractor's discretion with full knowledge of the currently accepted standards, hazards, risks and liabilities associated with asbestos work and asbestos containing products. By execution of this Contract the Contractor acknowledges the above and agrees to hold harmless, as set forth in the indemnity provisions of this Contract, the Owner, its employees, agents and assigns for all asbestos liability which may be associated with this work and agrees to instruct Contractor's employees and agents with respect to the above-mentioned standards, hazards, risks and liabilities.
- 2) The Contractor shall, prior to commencement of this work, provide a duly signed and notarized affidavit that Contractor has instructed Contractor's employees and agents with respect to the above mentioned standards, hazards, risks and liabilities and the contents and requirements of this portion of the Contract Documents.

d. Certification

The Contractor agrees that materials containing asbestos or other hazardous materials as defined in Federal and State law shall not be used in construction.

17. TEMPORARY FACILITIES

- a. The Contractor shall obtain permits for, install and maintain in safe condition all scaffolds, hoisting equipment, barricades, walkways, or other temporary structures that may be required to accomplish the work. Such structures shall be adequate for the intended use and capable of safely accepting all loads that may be imposed upon them. They shall be installed and maintained in accordance with all applicable codes and regulations.
- b. The Contractor shall provide and maintain temporary heat from an approved source whenever in the course of the work it may become necessary for curing, drying or warming spaces as may be required for the proper installation of materials or finishes. The Contractor shall provide and maintain any and all facilities that may be required for dewatering in order that work may proceed on the Project. If it is necessary for dewatering to occur continually, the Contractor shall have on hand whatever spare parts or equipment that may be required to avoid interruption of service or work.
- c. The Contractor shall promptly remove all such temporary facilities when they are no longer needed for the work or on completion of the Project. The Contractor shall repair any damage to premises or property which resulted from the construction, use, or removal of temporary facilities and shall restore the premises and property to their original condition.

- d. See the Supplemental General Conditions and/or specifications for requirements concerning temporary sanitary facilities and utilities.

18. SIGNS

No signs may be displayed on or about the District's property (except those which may be required by law) without the District's prior written approval of size, content and location. Any signs required by the District will be designated in the Supplemental General Conditions.

19. TIME

- a. The Contractor shall commence the work on the date indicated in the Notice to Proceed. Time is of the essence regarding the Contract work, and the Contractor shall prosecute the work diligently and regularly at such a rate of progress as to ensure completion of this Project within, or sooner than, the time specified.
- b. The Contractors and Subcontractors shall investigate and become aware of the amount of time required for the delivery of all equipment and materials required to perform the work under this Contract, and no extension of time shall be granted due to failure to order the equipment and materials sufficiently before their incorporation into the work so as to avoid delay to the Project.
- c. The Contractor and Subcontractors shall provide and maintain enough manpower, materials and equipment to ensure a rate of construction progress that will complete the Project within or sooner than the time specified and according to the schedule of work. If, in the District's opinion, the Contractor and/or Subcontractors are not prosecuting the work at a sufficient rate of progress to meet the Project schedule, the District may direct the Contractor to provide additional manpower, materials or equipment, or to work additional hours, holidays or weekends without additional cost to the District until the work is progressing in a manner satisfactory to the District. Failure to prosecute the work in a timely manner according to the Project schedule is considered a breach of Contract and shall be cause for termination of the Contract.

20. CONSTRUCTION SCHEDULE

- a. Within fifteen (15) calendar days after the award of the Contract, the Contractor shall prepare and submit to the Architect and District an as-planned construction schedule showing in detail how the Contractor plans to prosecute the work within the time set for Final Completion. The schedule shall include the work of all trades necessary for construction of the Project, and shall be sufficiently complete and comprehensive to enable progress to be monitored on a day-by-day basis. The information for each activity shall include at a minimum the activity description, duration, start date and completion date.
- b. The Contractor shall take care in the preparation of the schedule to ensure that it represents an accurate and efficient plan for accomplishing the work. If the Project is more than one week behind schedule, it must be promptly revised showing how the Contractor plans to

complete the work, but in no case shall it show a completion date later than that required by the Contract, unless a time extension has been granted. The current schedule shall be kept posted in the Contractor's project office on site.

- c. The Contractor shall be responsible for the coordination of all work necessary and pertaining to the construction whether actually a part of this Contract or attendant thereto. The Contractor shall notify the District and various utility companies, as far as possible in advance of their required work, in order that work schedules may be developed for all concerned, which will permit the most effective and timely accomplishment of the entire Project.

21. DELAYS AND TIME EXTENSIONS

- a. The Contractor may be granted a time extension if the Contractor encounters an unavoidable delay of the work due to causes completely beyond the Contractor's control and which the Contractor could not have avoided by the exercise of reasonable care, prudence, foresight and diligence. Causes for which a claim for extension of time may be made include: acts of the public enemy, acts of another contractor in the performance of another contract with the District, priority of a governmental agency for materials or equipment, fire, flood, violent wind storm, epidemic, quarantine restriction, strike, freight embargo, or weather of an unusually severe nature. The Contractor will not be granted time extensions for weather conditions which are normal for the location of the Project, according to the U. S. Weather Bureau Records.
- b. A request for extension of time and compensation related thereto shall be made in writing to the Architect and District within ten (10) calendar days of the date the delay is encountered, or shall be deemed waived. The request shall include a detailed description of the reasons for the delay and corrective measures by the Contractor. The request shall be accompanied by evidence that the insurance policies required by the Contract shall be in effect during the requested additional period of time. In order for the Architect to consider a request for time extension, the Contractor must prove that the reasons stated for the delay actually caused a delay in portions of the work which will result in completion beyond the date specified in the Contract. The Contractor may also be granted a time extension for a significant change in the scope of work which request for extension of time shall be included in a Contract modification proposal.
- c. No damages or compensation or any kind shall be paid to a Contractor because of delays in the progress of work, whether such delays be avoidable or unavoidable, that are not the responsibility of District. District's liability to Contractor for delays for which District is responsible shall be limited to an extension of time unless such delays were unreasonable under the circumstances involved and were not within the contemplation of the parties when the Contract was awarded. The Contractor shall provide to the District the actual, substantiated costs to Contractor for which the Contractor may claim damages from District. Such costs, if any, shall be directly related to the Project, and shall not include costs that would be borne by the Contractor in the regular course of business, including, but not limited to, office overhead and ongoing insurance costs. Delay damages shall not include

Contractor or Subcontractor markup for overhead and profit, but only actual, documented, and direct actual costs. The District shall not be liable for any damages which the Contractor could have avoided by any reasonable means including, but not limited to, the more judicious handling of forces or equipment.

- d. The granting of an extension of time because of unavoidable delays shall in no way operate as a waiver on the part of the District of the right to collect liquidated damages for other delays or of any other rights to which the District is entitled.

22. LIQUIDATED DAMAGES

- a. The parties understand and agree that the goodwill, educational process, and other business of District will be damaged if the Project is not completed within the time limits required. The parties have further agreed that the exact amount of damages for failure to complete the Work within the time specified is, in some cases, extremely difficult, impractical, or impossible to determine. As to those damages that are difficult, impractical, or impossible to determine, Should the Contractor fail to achieve Final Completion of this Contract within the time fixed for Final Completion, together with extensions granted by the District for unavoidable delays, Contractor shall become liable to the District in the amount specified in the Contract per calendar day for each day the Contract remains incomplete beyond the time for Final Completion, as liquidated damages and not as a penalty. Contractor shall not be charged with liquidated damages when the delay in completion of the work beyond the time for Final Completion is due to acts of the District.
- b. Any money due or to become due the Contractor may be retained to cover liquidated and other delay damages. Should such money not be sufficient to cover those damages, the District shall have the right to recover the balance from the Contractor or Contractor's sureties.
- c. Should the District authorize suspension of the work for any cause, the time work is suspended will be added to the time for completion. Suspension of the work by the District shall not be a waiver of the right to claim liquidated or other delay damages as set forth in this section.

23. DISTRICT'S RIGHT TO STOP WORK; TERMINATION OR SUSPENSION OF THE CONTRACT

a. District's Right to Stop Work:

In addition to or as an alternative to any and all other remedies available to the District, if the Contractor fails to correct work which is not performed in accordance with the Contract Documents, or if the Contractor persistently fails to perform the work in accordance with the Contract Documents, the District may by written order direct the Contractor to stop the work, or any portion thereof, until the cause for such order has been eliminated to the satisfaction of the District. However, the right of the District to stop the work shall not give rise to a duty on the part of the District to exercise this right for the benefit of the Contractor or any other person or entity, and the failure of the District to do so shall not be raised as a defense to the Contractor's failure to perform the work in accordance with the Contract Documents.

b. Termination for Cause:

- 1) If the Contractor refuses or fails to furnish sufficient materials, work force, equipment, and appurtenances to properly prosecute the work in a timely manner, or if Contractor refuses or fails to comply with any provisions of the Contract Documents, or if Contractor should file a bankruptcy petition or make a general assignment for the benefit of Contractor's creditors or if a receiver should be appointed on account of Contractor's insolvency, then the District may give the Contractor and Contractor's Surety written notice of intention to terminate the Contract. Unless within seven (7) calendar days after the serving of such notice upon the Contractor and Contractor's Surety such violation shall cease and arrangements for correction of such conditions shall be made satisfactory to the District, the Contract shall cease and terminate. In the event of such termination, the District shall immediately serve written notice thereof upon the Contractor and Contractor's Surety.
- 2) In the event of termination for cause, in addition to all remedies available to the District, the Contractor's Surety shall have the right to take over and perform the Contract; provided, however, that if the Surety does not commence performance within five (5) calendar days from the date of the issuance of such notice of termination, the District may take over the work and prosecute the same to completion by letting another Contract, or by any other method that the District deems advisable. The Contractor and Contractor's Surety shall be liable for any excess cost incurred by the District thereby, and in any such event the District may take possession of such materials, equipment, and other property belonging to the Contractor as may be on the site and use same in completing the work.

c. Termination or Suspension for Convenience:

The District reserves the right, in its sole discretion, to terminate or suspend all or part of the Contract for convenience following three (3) days written notice to the Contractor. In the event of termination or suspension for convenience, Contractor shall have no claims against the District, except:

- 1) The actual cost of labor, materials and services provided pursuant to the Contract, and which have not yet been paid for, as documented by timesheets, invoices, receipts and the like; and
- 2) Five percent (5%) of the total cost of the work performed as of the date of notice of termination or suspension or five percent (5%) of the value of the work yet to be completed, whichever is less. The parties agree that this amount shall constitute full and fair compensation for all Contractors lost profits and other damages resulting from the termination or suspension for convenience.

24. ASSIGNMENT OF CONTRACT

The Contractor may not assign or delegate all or any portion of this Contract without the written consent of the District and no such consent shall be given which would relieve the Contractor or its Surety of their responsibilities under the Contract. The Contractor may assign, without liability to the District, monies due the Contractor under the Contract to banks, trust companies or other financial institutions provided written notice thereof is promptly delivered to the District. Assignment of monies earned by the Contractor shall be subject to the same retention as other payments made to Contractor, and shall also be subject to setoffs and back charges as provided by this Contract.

25. COORDINATION WITH OTHER CONTRACTS

- a. The District reserves the right to do other work or award other contracts in connection with this Project. By entering into this Contract, Contractor acknowledges that there may be other contractors on or adjacent to the Project site whose work must be coordinated with that of its own. Contractor expressly warrants and agrees that it will cooperate with other contractors and will do nothing to delay, hinder, or interfere with the work of other contractors, or that of the District, its Architect and Construction Manager. Contractor also expressly agrees that in the event its work is hindered, delayed, interfered with, or otherwise affected by a separate contractor, its sole remedy will be a direct action against the separate contractor. To the extent allowed by law, the Contractor expressly waives any remedy against the District, its Architect and Construction Manager on account of delay, hindrance, interference or other such events caused by a separate contractor.
- b. If any part of Contractor's work depends upon the work of a separate contractor, Contractor shall inspect such other work and promptly report in writing to the District and Architect any defects in such other work that render it unsuitable to receive the work of Contractor. Failure of the Contractor to so inspect and report shall constitute an acceptance of the other

contractor's work, except as to defects which the Contractor could not have detected through the reasonable inspection of the other contractor's work prior to the execution of Contractor's work.

- c. If Contractor is aware of a current or potential conflict between Contractor's work and the work of another contractor on the site, and is unable to informally resolve the conflict directly with the other contractor, Contractor shall promptly provide written notice to the District, with a copy to the Architect and the other contractor, specifying the nature of the conflict, the date upon which the conflict arose, and the steps taken to attempt to resolve the conflict. The District may issue written instructions to address the conflict.
- d. If, through Contractor's negligence, any other contractor or subcontractor shall suffer loss or damage to the work, Contractor shall make a reasonable effort to settle with such other contractor and subcontractor by agreement or arbitration. If such other contractor or subcontractor shall assert any claim against the District or Architect, on account of any damage alleged to have been so sustained, the District or Architect shall notify the Contractor, who shall defend such proceedings at Contractor's own expense and save harmless and indemnify the District and the Architect from any such claim.

26. SUBMITTALS: SHOP DRAWINGS, CUTS AND SAMPLES

- a. Five (5) copies of shop drawings, brochures and cuts and samples in quantities specified by the Architect shall be submitted to the Architect for all items for which they are required by the plans and Specifications. Prior to transmittal, the Contractor shall examine all submittals for accuracy and completeness in order to verify their suitability for the work and compliance with the Contract Documents and shall sign and date each submittal. Submittals shall be made sufficiently before the items are required for the work so as to cause no delay and shall be in accordance with the Project construction schedule.
- b. In addition to information furnished as common practice, submittals shall contain the Project name and location, Contractor's name and address, Subcontractor's or supplier's name and address, date of submittal and any revisions, and reference to appropriate specification section, and/or drawing and detail numbers. The Contractor and/or the Subcontractors shall verify in the field all dimensions and relationships to adjacent work necessary to ensure the proper fit of the items submitted. If necessary, the Contractor shall make any corrections required and resubmit with all due haste in the same number as initially required.
- c. Review of submittals, shop drawings, cuts or samples by the District or Architect shall not relieve the Contractor from complying with the requirements of the Contract Documents.
- d. Any materials or equipment installed without approval shall be at the Contractor's own risk, and Contractor may be required to remove any such materials or equipment and install the specified items at Contractor's own cost, including repairs to adjacent work.

27. PAYMENTS

a. Cost Breakdown:

Prior to submitting Contractor's first request for payment, the Contractor shall prepare and submit to the Architect and District a cost breakdown (schedule of values) showing the major work items for each trade or operation required in construction of the Project. The work items shall be sufficiently detailed to enable the Architect to accurately evaluate the completion percentages requested by the Contractor. The cost for each work item shall include overhead and profit. The total of all work item costs shall equal the amount of the Contract.

b. Scope of Payment:

Payment to the Contractor at the unit price or other price fixed in the Contract for performing the work required under any item or at the lump sum price fixed in the Contract for performing all the work required under the Contract shall be full compensation for furnishing all labor, materials, equipment and tools necessary to the work, and for performing and completing, in accordance with the Specifications, all work required under the item or under the Contract, and for all expense incurred by the Contractor for any purpose in connection with the performance and completion of the work.

c. Progress Payments:

The Contractor will, on or about the last day of each month, make an estimate of the value of the work completed by Contractor in the performance of the Contract. These estimates shall be subject to the review and approval of the Architect. The first such estimate will be of the value of the work completed after the Contractor commenced the performance of the Contract, and every subsequent estimate, except the final estimate, will be of the value of the work completed since the immediately preceding estimate. Such estimates will be based on labor, materials and equipment incorporated into the work, and items of materials and equipment delivered to the Project. The Contractor shall be responsible for the security and protection of such materials and equipment delivered to the Project and not incorporated in the work. Within thirty (30) calendar days after the approval of each estimate for progress payment, the District will pay to the Contractor an amount equal to ninety five (95) percent of the approved estimate, unless a different retention percentage is stated in the Notice Inviting Bids, in which case that percentage applies. Payments may at any time be withheld if in the judgment of the District the work is not proceeding in accordance with the Contract Documents, the Contractor is not complying with the requirements of the Contract, stop notices have been timely filed, the estimate contains an error, or the District has incurred costs or requests reasonable financial assurances regarding defective work by the Contractor.

d. Final Payment:

Within thirty (30) days after all required work is fully completed in accordance with the Contract Documents, the Contractor shall submit a final invoice for the total value of the work completed in accordance with the Contract, which shall be subject to review and approval by the District. As required by law, District shall pay Contractor the unpaid balance of the Contract price of the work, or the whole Contract price of the work if no progress payment has been made, determined in accordance with the terms of the Contract, less such sums as may be lawfully retained under any provision of the Contract, including, but not limited to, amounts retained as liquidated damages, for stop notices, for third-party claims for which the Contractor is required to indemnify the District, for defective work and costs incurred by the District in connection therewith, or for other such claims and damages attributable to the Contractor (“Final Payment”). Prior progress estimates and payments are subject to correction in the Final Payment. Tender of the Final Payment shall constitute denial by the District of any unresolved claim. Contractor’s acceptance of the Final Payment shall operate as a full and final release to the District and its agents from any and all unasserted claims Contractor has, or may have, related to this Contract.

e. Payments Do Not Imply Acceptance of Work:

The granting of any progress payment or payments by the District or the receipt thereof by the Contractor shall not constitute acceptance of the work or of any portion thereof, and shall in no way lessen the liability of the Contractor to replace unsatisfactory work or material, whether or not the unsatisfactory character of such work or material was apparent or detected at the time such payment was made.

f. Retention of Sums Charged Against Contractor:

It is mutually understood and agreed that when under any provision of this Contract the District shall charge any sums of money against the Contractor, the amount of such charge shall be deducted and retained by the District from the amount of the next succeeding progress estimate, or from any other monies due or that may become due the Contractor on account of the Contract. If on completion or termination of the Contract such monies due the Contractor are found insufficient to cover the District's charges against the Contractor, the District shall have the right to recover the balance from the Contractor or the Contractor’s Sureties.

g. Release:

The Contractor and each assignee under an assignment in effect at the time of Final Payment shall, if required by the District, execute and deliver at the time of Final Payment and as a condition precedent to Final Payment, a release in form and substance satisfactory to and containing such exemptions as may be found appropriate by the District, discharging the District, its officers, agents and employees of and from liabilities, obligations and claims arising under this Contract.

h. Payment to Subcontractors and Suppliers:

The Contractor shall pay each Subcontractor and supplier promptly on receipt of each progress payment from the District for the materials, labor and equipment delivered to the site or incorporated in the work by each Subcontractor during the period for which the progress payment is made, less any retention as provided above.

i. Stop Notice Costs:

The District reserves the right to charge the Contractor or Surety, or to withhold from release of retention, all costs incurred by the District, including attorney’s fees, for processing and defending stop notice claims.

28. MODIFICATIONS OF CONTRACT

a. Changes In The Work:

- 1) The District, before the date of acceptance of the work, may, without notice to the Sureties, order changes in the work (“Modifications”), may order extra materials and extra work in connection with the performance of the Contract, and the Contractor shall promptly comply with such orders. All Modifications must be approved by DSA and the State Fire Marshall, if applicable, as required by law.
- 2) If changes ordered in design, workmanship or materials are of such a nature as to increase or decrease the cost of any part of the work, the price fixed in the Contract shall be increased or decreased by such amount as represents the reasonable and proper allowance for the increase or decrease in the cost of the work in accordance with the provisions of this Article, and any other applicable terms of the Contract, including, but not limited to, the Contractor’s schedule of values and the price for allowances, if any. Except as provided by law, the total cost of all Modifications shall not exceed ten (10) percent of the original Contract price.
- 3) In the case of a disputed work item, the District may direct the Contractor to perform the disputed work at no additional cost to the District on the grounds that the work is adequately indicated in the Contract Documents, and therefore already included in the Contract price. If the Contractor maintains that the disputed work represents a modification to the Contract, Contractor may submit a claim in accordance with Article 50, Resolution of Construction Claims. Notwithstanding any dispute regarding the requirements of the Contract Documents, Contractor shall promptly and fully comply with the District’s directive. Contractor’s failure to do so shall be deemed a material breach of this Contract, and in addition to all other remedies, District may, at its sole discretion, hire another contractor and/or use its own forces to complete the disputed work at Contractor’s sole expense, and may deduct the cost of such work from the Contract price.

b. Cost Breakdown:

When the Modification is proposed, the Contractor shall furnish a complete breakdown of actual costs of both credits and extras, itemizing materials, labor, taxes, overhead and profit. Subcontract work shall be so indicated. All costs must be fully documented. The following limitations shall apply:

1) Limitations Where Contract Price Changes are Involved:

- (a) Overhead and Profit for the Contractor. The Contractor's and any Subcontractor's overhead and profit on the cost of subcontracts shall be a sum not exceeding ten percent (10%) of such costs. The Contractor's and any Subcontractor's overhead and profit on the costs of work performed by the Contractor or Subcontractor shall be a sum not exceeding fifteen percent (15%) of such costs. Overhead and profit shall not be applied to the cost of taxes and insurance by Contractor or Subcontractors or to credits. No processing or similar fees may be charged by the Contractor in connection with the Modification. "Overhead and profit" shall include all plant, equipment rental and repair, project management, field coordination, job site project supervision and indirect labor and materials.
- (b) Bond Premiums. The actual rate of bond premiums as paid on the total cost (including taxes) will be allowed, but with no markup for profit and overhead.
- (c) Taxes. State and city sales taxes should be indicated. Federal excise tax shall not be included. (District will issue an exemption on request.)

2) Change Order Certification:

All change orders and requests for proposed change orders shall be deemed to include the following certification by the Contractor:

"The undersigned Contractor approves the foregoing as to the changes in work, if any, and as to the Contract price specified for each item and as to the extension of time allowed, if any, for completion of the Project as stated herein, and agrees to furnish all labor, materials, and service and to perform all work necessary to complete any additional work specified for the consideration stated herein. Submission of claims which have no basis in fact or which Contractor knows are false are made at the sole risk of the Contractor and may be a violation of the False Claims Act, as set forth in Government Code §§12650 *et seq.* It is understood that the changes to the Contract Documents set forth herein shall only be effective upon approval by the Governing Board of the District.

"It is expressly understood that the value of the extra work or changes expressly includes any and all of the Contractor's costs and expenses, both direct and indirect,

resulting from additional time required on the Project or resulting from delay to the Project. Any costs, expenses, damages, or time extensions not included herein are deemed waived."

c. Unit Prices, Schedule of Values, or Allowances:

Where Unit Prices, a Schedule of Values, and/or Allowances are required by the Contract Documents, that pricing shall govern in computing any additions to or deductions from the Contract price on account of any added or omitted work. Unit Prices listed in the original bid include all costs and no addition of any description will be allowed.

d. Time and Materials:

If it is impractical, because of the nature of the work, or for any other reason, to fix an increase in price in advance, the Change Order may fix a maximum price which shall not under any circumstances be exceeded, and subject to such limitation, such alteration, modification or extra shall be paid for at the actual necessary cost as determined by the sum of the following items (1) to (5) inclusive:

- 1) Labor, including premium on compensation insurance and charge for Social Security taxes, and other taxes pertaining to labor.
- 2) Material, including sales taxes and other taxes pertaining to materials.
- 3) Plant and equipment rental, to be agreed upon in writing before the work is begun. No charge for the cost of repairs to plant or equipment will be allowed.
- 4) Overhead and profit computed at fifteen percent (15%) of the total of Items (1) to (3) inclusive.
- 5) The proportionate cost of premiums on bonds computed at one and one-half percent (1-1/2%) of the total of items (1) to (4) inclusive.

If the Time and Materials work is done by a Subcontractor, the amount shall be determined as set forth above under items (1) to (5) inclusive. The Contractor's overhead and profit on the costs of subcontracts (exclusive of taxes and insurance) shall not exceed ten percent (10%) of such costs.

The District reserves the right to furnish such materials as it may deem expedient, and no allowance will be made for profit thereon. The above-described methods of determining the payment for work and materials shall not apply to the performance of any work or the furnishing of any material which, in the judgment of the District, may properly be classified under items for which prices are established in the Contract.

e. Oral Modifications:

No oral statements of any person shall in any manner or degree modify or otherwise affect the terms of the Contract.

29. INDEMNITY

Contractor shall defend with counsel acceptable to the District, indemnify and hold harmless to the full extent permitted by law, the District and its Board of Trustees, officers, agents, Architect, construction manager, employees and volunteers from and against any and all liability, loss, damage, claims, expenses, fines, judgments and costs (including, without limitation, attorney's fees and costs and fees of litigation) (collectively, "Liability") of every nature arising out of or in connection with Contractor's performance of the Project or its failure to comply with any of its obligations contained in these Contract Documents, except such Liability caused by the active negligence, sole negligence or willful misconduct of the District. Such indemnification shall extend to all claims, demands, or liabilities occurring after completion of the project as well as during the progress of the work. Pursuant to Public Contract Code §9201, District shall timely notify Contractor of receipt of any third-party claim relating to this Project.

30. WARRANTY OF TITLE

Contractor warrants that title to all work, materials or equipment included in a request for payment shall pass and transfer to the District whether or not they are installed or incorporated in the Project, free from any claims, liens or encumbrances, when such payment is made to the Contractor. Contractor further warrants that no such work, materials or equipment have been purchased for work under the Contract subject to an agreement by which an interest therein or an encumbrance thereon is retained by the seller or supplier.

31. USE OF COMPLETED PARTS OF THE WORK BEFORE ACCEPTANCE

Whenever the work or any part thereof is in a condition suitable for use, and the best interest of the District requires such use, as determined by the District, the District may take possession of, connect to, open for public use, or use the work or a part thereof. When so used, maintenance and repairs due to ordinary wear and tear or vandalism will be made at District's expense. The use by the District of the work or part thereof as contemplated in this section shall in no case be construed as constituting acceptance of the work or any part thereof, including, but not limited to, the right to assess liquidated damages. Such use shall neither relieve the Contractor of any of Contractor's responsibilities under the Contract nor act as a waiver by the District of any of the conditions thereof. Contractor shall continue to maintain all insurance, including Builder's Risk insurance, on the entire Project, and diligently pursue full completion of the work.

32. GUARANTEE AND WARRANTY

- a. By signing this Contract, Contractor agrees to the following guarantee and warranty:

Guarantee & Warranty

Contractor hereby guarantees and warrants its work on the Project for a period of two (2) years from the date of the filing of the Notice of Completion as follows.

Contractor shall promptly repair or replace to the satisfaction of the District any or all work that appears defective in workmanship, equipment and/or materials for whatever reason, ordinary wear and tear and unusual abuse or neglect excepted, together with any other work which may be damaged or displaced in so doing.

Contractor agrees to promptly correct and remedy any failure by the Contractor to conform its work, activities and services to the requirements of the Contract Documents.

In the event of the Contractor's failure to comply with the above-mentioned obligations within the ten (10) calendar days of notice, or sooner if required by an emergency, Contractor hereby authorizes the District to have the defects or deficiencies repaired, remedied, corrected and made good at Contractor's expense, and Contractor shall pay the costs and charges therefore upon demand. The Surety agrees to be responsible for these costs and charges as well.

33. PROTECTION OF WORK AND PROPERTY

- a. The Contractor shall be responsible for each operation and all work on the Project, both permanent and temporary. The Contractor shall protect the work and materials from damage due to negligence, the action of the elements, the carelessness of third parties, vandalism, or any other cause whatsoever, until the final completion and acceptance of the Project. Should improper work by the Contractor be covered by another contractor and damage or defects result, the whole work affected shall be made good by the Contractor to the satisfaction of the Architect and District without expense to the District. The Contractor shall take reasonable care to avoid damage to existing facilities or utilities, whether on the Project or adjacent to it, and Contractor shall be liable for any damage thereto or interruption of service due to Contractor's operations. If the Contractor encounters any facilities or utilities not shown on the drawings or not reasonably inferable therefrom, Contractor shall promptly notify the Architect about them, and shall do no further work which may cause damage to same. If it is determined that some action needs to be taken regarding facilities not shown,

the Contractor will be given directives on what action to take, and any additional cost to the Contractor incurred thereby will be handled by Change Order.

- b. The property limits of the area of the Project are indicated on the drawings. Except for work specifically shown or noted, Contractor shall confine Contractor's operations within the indicated property limits. The Contractor shall provide, install, and maintain all shoring, bracing and underpinning necessary to support adjacent property, streets, buildings and structures, that may be affected by building operations for this work; shall serve or cause to be served all legal notices to adjoining property owners that may be necessary for their protection; and shall protect from damage all adjacent buildings, fences, landscaping, and repair or replace any such property damaged in the course of work under the Contract.

34. USE OF ROADWAYS AND WALKWAYS

The Contractor shall not unnecessarily interfere with use of any roadway, walkway or other facility for vehicular or pedestrian traffic by any party entitled to use it. Wherever such interference becomes necessary for the proper and convenient performance of the work and no satisfactory detour route exists, the Contractor shall, before beginning the interference, provide a satisfactory detour, temporary bridge, or other proper facility for traffic to pass around or over the interference and shall maintain it in satisfactory condition as long as the interference continues, all without extra payment unless otherwise expressly stipulated in the Contract Documents.

35. MATERIALS

- a. Unless explicitly stated otherwise, all specified equipment and material comprising the work of this Contract, as being provided or furnished or installed, shall imply the inclusion of all components, hardware and accessories, required for complete installation and satisfactory operation as intended by the manufacturer. Wherever the method of installation of any material is not explicitly specified, the installation shall be as recommended by manufacturer.
- b. Wherever in the Contract Documents it is provided that the Contractor shall furnish materials or equipment for which no detailed specifications are set forth, such materials or equipment shall be new and of the best grade for the purpose for which they will be used when incorporated in the work. Materials specified by reference to a number or symbol of a specific standard, such as A.S.M., Federal Specification, State Standard, Trade Association, or similar standards, shall comply with requirements in the latest revision thereof and any amendment or supplement in effect on the date of the notice inviting bids.
- c. None of the materials to be provided furnished or installed on this project shall contain asbestos or any other "hazardous substance" as that term is defined by federal or state law.

36. SUBSTITUTIONS

- a. Wherever in the drawings or Specifications a material or product is called for by trade or brand names or manufacturer and model number, alternative items of equal quality and purpose may be proposed for use by the Contractor. The burden of proof of equality is on the Contractor, and Contractor shall furnish all information and supplies necessary for the Architect to make a thorough evaluation of the proposed substitution. The Architect's decision about the equality of the proposed substitution is final, and if the proposed substitution is not approved, the Contractor shall install the item called for. Proposed substitutions and any changes in adjacent work caused by them shall be made by the Contractor at no additional cost to the District.
- b. Proposed substitutions shall be submitted sufficiently before actual need to allow time for thorough evaluation. Substitutions shall not be proposed for the reason that submittals were not made early enough to avoid delay. Architect's review of substitutions shall not relieve the Contractor from complying with the requirements of the drawings and Specifications.
- c. In the event Contractor makes substitutions in materials, equipment, or designs, with or without the District's approval, other than those authorized herein, the Contractor shall then assume full responsibility for the effects of such substitutions on the entire Project, including the design, and shall reimburse the District for any charges resulting from such substitutions, including any charges for modifications in the work of other trades, and including any charges for additional design and review, plus reasonable and customary mark-ups.

37. TESTING

- a. Materials, equipment, or other work requiring tests may be specified in the Contract Documents, and they shall be adequately identified and delivered to the site in ample time before intended use to allow for testing. If such materials, equipment or other work should be covered without required testing and approval, they shall be uncovered at the Contractor's expense, including any repairs or replacement resulting therefrom. The Contractor shall notify the District and Architect when and where such materials, equipment or other work are ready for testing, and Contractor shall bear the cost of making them available for testing. The Contractor shall notify the District and Architect sufficiently before the need for testing so as to cause no delay in the work and, in any case, at least forty-eight (48) hours prior to the need for testing.
- b. The cost of initial tests called for will be paid by the District and will be performed by independent testing consultants retained by the District, but if so specified by the District, the amount paid or a portion thereof may be collected from the Contractor. All other tests and inspections specified or otherwise required to substantiate compliance with specified requirements for quality of material or performance of operation shall be paid for by the District, but if so specified by the District, the amount paid may be collected from the Contractor. If retesting or additional testing is necessary because of substandard initial test results, the costs thereof shall be paid by the District, but if so specified by the District, the

amount paid may be collected from the Contractor, including any repairs or replacement resulting therefrom.

38. INSPECTION

- a. All materials, equipment and workmanship used in the work of the Project shall be subject to inspection or testing at all times and locations during construction and/or manufacture. The District's and Architect's authorized representatives and representatives of other agencies having authority over the work shall have access to the work for the above purposes at all reasonable times and locations. Any material or work found to be unsatisfactory or not according to the Contract Documents shall be replaced with the correct material or work and the defective items promptly removed, all at the Contractor's expense, when directed to do so by any of the above-named persons having authority over the work. The cost of review time and analysis by the Architect or other District consultants necessitated by incomplete or defective work by the Contractor shall be charged to the Contractor.
- b. Inspection and testing by the District or its representatives shall not relieve the Contractor from complying with the requirements of the Contract Documents. The Contractor is responsible for its own quality control.
- c. Whenever required by the District or Architect, the Contractor shall furnish all tools, labor and materials necessary to make an examination of work in place by uncovering the same. Should such work be found unsatisfactory, the cost of examination and reconstruction shall be paid by the Contractor. Should such work be found satisfactory, the cost of examination and reconstruction of the work shall be paid by Change Order unless the Contractor improperly covered the work before it could be inspected or tested. If the Contractor considers it necessary or desirable to work on Saturday, Sunday or a holiday, Contractor shall seek written approval from the District at least forty-eight (48) hours before the commencement of such work.

39. CLEANUP

- a. The Contractor shall maintain the premises and area of the work in a neat and clean condition. No burning of rubbish on site shall be allowed. The Contractor shall control dust on the site by sprinkling at whatever intervals are necessary to keep it laid down and shall take measures to prevent dust and debris from being accidentally transported outside the area of the work.
- b. Final cleaning, such as sweeping, dusting, vacuuming, dry and wet mopping, polishing, sealing, waxing and other finish operations normally required on newly installed work shall be taken to indicate the finished conditions of the various new and existing surfaces at the time of acceptance. Prior to the time of acceptance, all marks, stains, fingerprints, dust, dirt, splattered paint and blemishes resulting from the various operations shall be removed throughout the Project. Stair treads and risers shall be wet-mopped. Glass shall be left clean and polished both inside and outside. Plumbing fixtures and light fixtures shall be washed clean. Hardware and other unpainted metals shall be cleaned and all building papers and

other temporary protections shall be removed throughout the building, or portion of the building where Contractor was involved, all to the satisfaction of the Architect and District. The exterior of the buildings, playfields, exterior improvements, and planting spaces and other work areas shall be similarly clean and in good order.

40. CONSTRUCTION WASTE MANAGEMENT REQUIREMENTS

a. Scope

- 1) This Article includes requirements for the diversion by the Contractor of construction and demolition debris from landfills. The Contractor shall develop and implement a Waste Management Plan as specified herein. The Contractor shall take a pro-active, responsible role in the management of construction and demolition waste and require all subcontractors, vendors, and suppliers to participate in the effort.
- 2) The District has established that this Project shall generate the least amount of waste practicable and that processes shall be utilized that ensure the generation of as little waste as possible due to over-packaging, error, poor planning, breakage, mishandling, contamination or other factors.
- 3) As much of the waste materials as economically feasible shall be reused, salvaged or recycled. Waste disposal in landfills shall be minimized.
- 4) The Contractor is encouraged to use waste hauling companies that separate recyclable materials. The Contractor shall work with its waste haulers in providing other recycling methods as appropriate.
- 5) The Contractor is responsible for implementation of any special programs involving rebates or similar incentives related to the recycling of waste. Revenues or other savings obtained for salvage or recycling accrue to the Contractor.

b. References

- 1) "Builders' Guide to Reuse and Recycling, A Directory for Construction and Demolition Materials."
- 2) "Construction Site Recycling, a Guide for Building Contractors ". For a copy of the guide call 1-888-442-2666 or go to www.recycleworks.org.
- 3) "Where to Recycle Construction and Demolition Debris." For a copy of the guide call 1-888-442-2666 or go to www.recycleworks.org.

c. Definitions

- 1) General: Construction and demolition waste includes products of demolition or

removal, excess or unusable construction materials, packaging materials for construction products, and other materials generated during the construction process but not incorporated into the work.

- 2) Divert" means to use material for any lawful purpose other than disposal in a landfill or transfer facility for disposal
- 3) "Recycling Service" means an off-site service that provides processing of material and diversion from a landfill.
- 4) "Hauler" means the entity that transports construction and demolition debris to either a landfill or a recycling service.

d. Compliance with regulatory requirements:

- 1) The Contractor shall perform all handling, storage, transportation and disposal of construction debris in compliance with all applicable Federal, State, regional, and local statutes, laws, regulations, rules, ordinance, codes and standards.
- 2) Nothing stated on the drawings, in this Article 40 or in any other provision of the Contract Documents shall be construed as allowing work that is not in strict compliance with all applicable Federal, State, regional, and local statutes, laws, regulations, rules, ordinances, codes and standards.

e. Performance Requirement

- 1) The Contractor shall divert a minimum of 50 percent (50%) of the total Project construction and demolition waste from landfills.

f. Quality Control

- 1) General:
 - i) The Contractor shall not permit materials designated for diversion to become contaminated or to contaminate the site or surrounding areas.
- 2) Training and Coordination:
 - i) The Contractor shall designate an on-site party [or parties] who will be responsible for instructing workers and subcontractors, and overseeing and documenting the results of the Waste Management Plan for the Project.
 - ii) The Contractor shall furnish copies of the Waste Management Plan to all on-site supervisors, each subcontractor, and the District's representative.
 - iii) The Contractor shall include construction waste management

as an item on the agenda of all progress meetings.

- 3) The Waste Management Plan:
 - i) The Contractor shall prepare a Waste Management Plan for diverting the specified percentage of construction debris from landfills, including written and graphic information indicating how the waste will be diverted.
 - ii) Include in the plan both on-site recycling of construction debris and off-site diversion from landfills.
 - iii) Identify the means and methods for collecting and separating each type of debris deemed reusable or recyclable.
 - iv) List the off-site recycling service and hauler of each designated debris item who has agreed to accept and divert that item from the landfill in the proposed quantities anticipated. List the service and hauler company name, address, telephone number, and persons contacted.
 - v) List the name of individuals on the Contractor's staff responsible for waste prevention and management.
 - vi) List the actions that will be taken to reduce solid waste generation, including coordination with subcontractors to ensure awareness and participation.
 - vii) Describe the specific approaches to be used in recycling/reuse of the various materials generated, including the areas on site and equipment to be used for processing, sorting, and temporary storage of wastes.
 - viii) Characterize the waste to be generated, including estimated types and quantities. Name the landfills and/or incinerator to be used.
 - ix) List the specific waste materials that will be salvaged for resale, salvaged and reused on the Project, salvaged and stored for reuse on a future project, or recycled. Recycling facilities that will be used shall be identified by name, location, and phone number.
 - x) Identify the materials that cannot be recycled or reused with an explanation or justification, to be approved by the Architect.

The Contractor shall submit the Plan to the Architect within 10 calendar days after receipt of the Notice to Proceed, or prior to any waste removal, whichever occurs first. The Contractor shall promptly revise and resubmit the Plan as required by the Architect. Review of the Contractor's Waste Management Plan will not relieve the Contractor of responsibility for compliance with applicable environmental regulations or meeting Project diversion requirements.

g. Plan Implementation

- 1) The Contractor shall implement the approved Waste Management Plan.
- 2) The Contractor shall maintain a log of each load and of each category of waste that is diverted from the landfill. The Contractor shall separately log the debris sent to a Class III landfill and materials sent to recycling facilities.
- 3) The Contractor shall include in the log the type of load, load weight, name of the hauling service, recycling service or landfill, and the date accepted by the recycling service or by the landfill.
- 4) The Contractor shall retain and make available all weight tickets and copies of receipts and invoices relating to the implementation of the Plan.
- 5) The District reserves the right to audit the log at any time.

h. Material Handling

- 1) Designate a specific area or areas on site to facilitate the separation of materials for potential reuse, salvage, recycling, and return. Clearly mark bins for each category of waste.
- 2) Keep waste bins and pile areas neat and clean. Do not contaminate non-recyclable waste with materials designated for reuse or recycling.

i. Contractor's Responsibilities

- 1) Provide on-site instruction of the appropriate separation, handling, recycling, salvage, reuse, and return methods to be used by all parties at the appropriate stages of the Project.
- 2) Separate, store, protect, and handle at the site identified recyclable and salvageable waste products in a manner that maximizes recyclability and salvagability of identified materials. Provide the necessary containers, bins and storage areas to facilitate effective waste management. Provide barriers and enclosures around recyclable material storage areas which are non hazardous and recyclable or reusable and which shall be located away from construction traffic. Provide adequate space for pick-up and delivery. Use cleaning materials that are non hazardous and biodegradable.

41. INSTRUCTIONS AND MANUALS

Three copies of the maintenance instructions, application/installation instructions and service manuals called for in the Specifications shall be provided by the Contractor. These shall be complete as to drawings, details, parts lists, performance data and other information that may be required for

the District to easily maintain and service the materials and equipment installed under this Contract. All manufacturer's application/installation instructions shall be given to the Architect at least ten (10) days prior to first material application or installation of the item. The maintenance instructions and manuals, along with any specified guarantees, shall be delivered to the Architect for review prior to submitting to District, and the Contractor or appropriate Subcontractors shall instruct District's personnel in the operation and maintenance of the equipment prior to final acceptance of the Project.

42. AS-BUILT DRAWINGS

The Contractor and all Subcontractors shall maintain on the work site a separate complete set of contract drawings which will be used solely for the purpose of recording changes made in any portion of the work during the course of construction, regardless of the reason for the change. As changes occur, there will be included or marked on this record set on a daily basis if necessary to keep them up to date at all times. Actual locations to scale shall be identified on the drawings for all runs of mechanical and electrical work, including all site utilities installed underground, in walls, floors, and furred spaces, or otherwise concealed. Deviations from the drawings shall be shown in detail. All main runs, whether piping, conduit, duct work, drain lines, etc., shall be located in addition by dimension and elevation. Progress payments may be delayed or withheld until such time as the record set is brought up to date to the satisfaction of the Architect. The Contractor shall verify that all changes in the work are included in the "AS-BUILT" drawings and deliver the complete set thereof to the Architect for review and approval within thirty (30) calendar days after District's notice of completion. District's acceptance and approval of the "AS-BUILT" drawings are a necessary condition precedent to the release of the final retention.

43. SUBSTITUTION OF SECURITIES

- a. Pursuant to Public Contract Code §22300, Contractor may request in writing that it be allowed at its own expense to substitute securities for moneys withheld by District to ensure performance under this Contract. Only securities listed in Government Code §16430 and bank or savings and loan certificates of deposit, interest-bearing demand deposit accounts, standby letters of credit, or any other security mutually agreed to by Contractor and District shall qualify under this Article. Securities equivalent to the amount withheld shall be deposited with the District or with a state or federally chartered bank in California as the escrow agent. Upon satisfactory completion of the Contract and on written authorization by the District, the securities shall be returned to Contractor. Contractor shall be the beneficial owner of the securities and shall receive any interest thereon. The Contractor may alternatively request District to make payment of retentions earned directly to the escrow agent at the expense of the Contractor.
- b. At the expense of the Contractor, the Contractor may direct the investment of the payments into securities and the Contractor shall receive the interest earned on the investments upon the same terms provided for above for securities deposited by Contractor. Upon satisfactory completion of the Contract, Contractor shall receive from the escrow agent all securities, interest, and payments received by the escrow agent from the District. The Contractor shall pay to each Subcontractor, not later than 20 days of receipt of payment, the respective

amount of interest earned, net of costs attributed to retention withheld from each Subcontractor, on the amount of retention.

- c. Any escrow agreement entered into pursuant to this Article shall comply with Public Contract Code §22300 and shall be subject to approval by District's counsel.

44. NO DISCRIMINATION

It is the policy of the District that, in connection with all work performed under this public works contract, there shall be no discrimination against any prospective or active employee or any other person engaged in the work because of actual or perceived race, color, ancestry, national origin, ethnic group identification, religion, sex, gender, sexual orientation, age, physical or mental disability, or marital status. The Contractor agrees to comply with applicable Federal and California laws including, but not limited to, the California Fair Employment Practice Act, beginning with Government Code §12900, Government Code §11135, and Labor Code §§ 1735, 1777.5, 1777.6 and 3077.5. In addition, the Contractor agrees to require like compliance by all Subcontractors and suppliers.

45. LABOR STANDARDS

- a. Work Hours:

In accordance with Labor Code §1810, eight (8) hours of labor shall constitute a legal day's work under this Contract. Contractor and any Subcontractor shall pay workers overtime pay as required by Labor Code §1815. The Contractor shall pay each worker, laborer, mechanic or persons performing work under this Contract at a rate not less than the prevailing wage for each craft or classification covering the work actually performed.

- b. Penalty:

Contractor shall forfeit to District as a penalty the sum of twenty-five dollars (\$25.00) for each worker employed in the execution of this Contract by Contractor or any Subcontractor for each calendar day during which the worker is required or permitted to work more than eight (8) hours in any one (1) calendar day or more than forty (40) hours per calendar week in violation of Article 3, Division 2, Part 7, Chapter 1 of the California Labor Code.

- c. Employment of Apprentices:

Contractor shall comply with Labor Code §§1773.3, 1777.5 and 1777.6, and 3077 *et. seq.*, each of which is incorporated by reference into this Contract. These sections require that contractors and subcontractors employ apprentices in apprenticeable occupations in a ratio of not less than one (1) hour of apprentice work for every five (5) hours of labor performed by a journeyman, unless an exception is granted and that Contractors and Subcontractors shall not discriminate against otherwise qualified employees as apprentices on any public works solely on the ground of actual or perceived race, religion, color, national origin, ethnic group identification, sex, gender, sexual orientation, age, or physical or mental disability.

Only apprentices who are in training under written apprenticeship occupations shall be employed. The responsibility for compliance with these provisions for all apprenticeable occupations rests with Contractor.

- d. The Contractor shall be knowledgeable of and comply with Labor Code §§1727, 1773.5, 1775, 1777, 1777.5, 1810, 1813, 1860, including all amendments thereto; each of these sections is incorporated by reference into this Contract.

46. GENERAL RATE OF PER DIEM WAGES

- a. On File:

As required by Labor Code §1773.2, the District has available copies of the general prevailing rate of per diem wages for workers employed on public work as determined by the Director of the Department of Industrial Relations, which shall be available to any interested party on request. Contractor shall post a copy of the document at each job site.

- b. Prevailing Wage Rate:

The Contractor and each Subcontractor shall pay each worker performing work under this Contract at a rate not less than the prevailing wage as defined in Labor Code §1771 and 1774 and §16000(a) of Title 8, California Code of Regulations.

- c. Penalty:

In accordance with §1775 of the Labor Code, the Contractor shall forfeit to the District as penalty, the sum of \$200 for each calendar day, or portion thereof, for each worker paid less than the prevailing wage rates, as determined by the Director of the California Department of Industrial Relations, for any work done under this Contract by Contractor or by any Subcontractor. Contractor shall also pay each worker the difference between the stipulated prevailing wages rates and the amount actually paid to such worker.

47. RECORD KEEPING

- a. The Contractor agrees to comply with the provisions of §§1776 and 1812 of the Labor Code. The Contractor and each Subcontractor shall keep or cause to be kept an accurate record showing the names, addresses, social security numbers, work classifications, straight time and overtime hours worked each day and week of all workers employed by Contractor in connection with the execution of this Contract or any subcontract thereunder and showing the actual per diem wages paid to each of such workers. These records shall be certified and shall be open at all reasonable hours to the inspection of the District awarding the Contract, its officers and agents, and to the Chief of the Division of Labor Statistics and Law Enforcement of the State Department of Industrial Law Enforcement of the State Department of Industrial Relations, and his or her other deputies and agents.

- b. In addition, copies of the above records shall be available as follows:
 - 1) A certified copy of an employee's payroll record shall be made available for inspection or furnished to the employee or his or her authorized representative on request;
 - 2) A certified copy of all payroll records shall be made available for inspection or furnished upon request to the District, the Division of Labor Standards Enforcement, and the Division of Apprenticeship Standards of the Department of Industrial Relations;
 - 3) A certified copy of all payroll records shall be made available upon request by the public for inspection or copies thereof made; provided, however, that a request by the public shall be made through either the District, the Division of Apprenticeship Standards, or the Division of Labor Standards Enforcement. If the requested payroll records have not been previously provided, the requesting party shall, prior to being provided the records, reimburse the costs of the Contractor, Subcontractors, and the entity through which the request was made. The public shall not be given access to the records at the principal office of the Contractor.
- c. The Contractor shall file a certified copy of the records with the entity requesting the records within ten days after receipt of a written request. Any copy of records made available for inspection as copies and furnished upon request to the public or any public agency by the District, shall be marked or obliterated in such a manner as to prevent disclosure of an individual's name, address, and social security number. The name and address of the Contractor awarded the Contract or performing the Contract shall not be marked or obliterated.
- d. The Contractor shall inform the Owner of the location of the records, including the street address, city and county, and shall, within five working days, provide a notice of a change of location and address.
- e. In the event of noncompliance with the requirements of this section, the Contractor shall have ten days in which to comply subsequent to receipt of written notice specifying in what respects the Contractor must comply with this section. Should noncompliance still be evident after the ten day period, the Contractor shall, as a penalty to the District, forfeit \$100 for each calendar day, or portion thereof, for each worker, until strict compliance is effectuated. Upon the request of the Division of Apprenticeship Standards or the Division of Labor Standards Enforcement, these penalties shall be withheld from progress payments then due.

- f. Responsibility for compliance with this provision shall be with the Contractor.

48. PROJECT COMPLETION

- a. When all of the work to be performed under this Contract has been fully completed, the Contractor shall notify the Architect and District, in writing, setting a date for inspection. The Contractor and Subcontractor representatives shall attend the inspection. As a result of this inspection, the Architect will prepare a list of items ("punch list") that are incomplete or not installed according to the Contract Documents. Failure to include items on this list does not relieve the Contractor from fulfilling all requirements of the Contract Documents.
- b. The Architect will promptly deliver the punch list to the Contractor and it will include a period of time by which the Contractor shall complete all items listed thereon. On completion of all items on the punch list, verified by a final inspection, and all other Contract requirements, so that Final Completion has been achieved to the District's satisfaction, the District will file a Notice of Completion with the County Recorder. Payment of retention from the Contract, less any sums withheld pursuant to the terms of this Contract or applicable law, shall not be made sooner than thirty-five (35) calendar days after the date of filing of Notice of Completion.
- c. The District reserves the right to occupy buildings and/or portions of the site at any time before Completion, and occupancy shall not constitute final acceptance of any part of the Work covered by the Contract Documents, nor shall such occupancy extend the date specified for completion of the Work. Beneficial occupancy of building(s) does not commence any warranty period or entitle Contractor to any additional compensation due to such occupancy, or affect in any way or amount Contractor's obligation to pay liquidated damages for failure to complete the Project on time.

49. TRENCHING OR OTHER EXCAVATIONS

- a. Excavations or Trenches Deeper than Four Feet:

If the Project involves digging trenches or other excavations that extend deeper than four feet, the following provisions shall be a part of this Contract:

- 1) The Contractor shall promptly, and before the following conditions are disturbed, provide written notice to the District if the Contractor finds any of the following conditions:
 - (a) Material that the Contractor believes may be a hazardous waste, as defined in §25117 of the Health and Safety Code, which is required to be removed to a Class I, Class II, or Class III disposal site in accordance with the provisions of existing law.
 - (b) Subsurface or latent physical conditions at the site which are different from those indicated or expected.

(c) Unknown physical conditions at the site of any unusual nature or which are materially different from those ordinarily encountered and generally recognized as inherent in work which the Contractor generally performs.

2) In the event that the Contractor notifies the District that Contractor has found any of the conditions specified in subparagraphs (a), (b) or (c), above, the District shall promptly investigate the condition(s). If the District finds that the conditions are materially different or that a hazardous waste is present at the site which will affect the Contractor's cost of, or the time required for, performance of the Contract, the District shall issue a change order in accordance with the procedures set forth in this Contract.

3) In the event that a dispute arises between the District and the Contractor regarding any of the matters specified in Paragraph (2), above, the Contractor shall proceed with all work to be performed under the Contract and the Contractor shall not be excused from completing the Project as provided in the Contract. In performing the work pursuant to this Paragraph, the Contractor retains all rights provided by Article 50 which pertains to the resolution of disputes between the contracting parties.

b. Regional Notification Center:

The Contractor, except in an emergency, shall contact the appropriate regional notification center at least two (2) days prior to commencing any excavation if the excavation will be conducted in an area that is known, or reasonably should be known, to contain subsurface installations other than the underground facilities owned or operated by the District, and obtain an inquiry identification number from that notification center. No excavation shall be commenced and/or carried out by the Contractor unless an inquiry identification number has been assigned to the Contractor or any Subcontractor and the Contractor has given the District the identification number. Any damages or delays arising from Contractor's failure to make appropriate notification shall be at the sole risk and expense of the Contractor and shall not be considered for an extension of the Contract time.

c. Existing Utility Lines:

1) Pursuant to Government Code §4215, the District assumes the responsibility for removal, relocation, and protection of main or trunk utility lines and facilities located on the construction site at the time of commencement of construction under this Contract with respect to any such utility facilities that are not identified in the plans and Specifications. Contractor shall not be assessed liquidated damages for delay in completion of the Project caused by the failure of the District or the owner of a utility to provide for removal or relocation of such utility facilities.

2) Locations of existing utilities provided by the District shall not be considered exact, but approximate within reasonable margin and shall not relieve Contractor of responsibilities to exercise reasonable care nor costs of repair due to Contractor's failure to do so. The District shall compensate Contractor for the costs of locating

and repairing damage not due to the failure of Contractor to exercise reasonable care, and removing or relocating such utility facilities not indicated in the plans and Specifications with reasonable accuracy.

- 3) No provision herein shall be construed to preclude assessment against Contractor for any other delays in completion of the Project. Nothing in this section shall be deemed to require the District to indicate the presence of existing service laterals, appurtenances, or other utility lines, with the exception of main or trunklines, whenever the presence of such utilities on the site of the construction Project can be inferred from the presence of other visible facilities, such as buildings, meter and junction boxes, on or adjacent to the site of the construction.
- 4) If Contractor, while performing work under this Contract, discovers utility facilities not identified by the District in the Project plans and Specifications, Contractor shall immediately notify the District and the utility in writing. The cost of repair for damage to above-mentioned visible facilities without prior written notification to the District shall be borne by the Contractor.

d. Prompt Notification:

Contractor understands, acknowledges and agrees that the purpose for prompt notification to the District pursuant to these provisions is to allow the District to investigate the condition(s) so that the District shall have the opportunity to decide how the District desires to proceed as a result of the conditions. Accordingly, failure of Contractor to promptly notify the District in writing, pursuant to these provisions, shall constitute Contractor's waiver of any claim for damages incurred as a result of the conditions.

e. Trenches Five Feet and Deeper:

Pursuant to Labor Code §6705, if the Contract price exceeds \$25,000 and involves the excavation of any trench or trenches five (5) feet or more in depth, the Contractor shall, in advance of excavation, promptly submit to the District and/or a registered civil or structural engineer employed by the District or Architect, a detailed plan showing the design of shoring for protection from the hazard of caving ground during the excavation of such trench or trenches.

50. RESOLUTION OF CONSTRUCTION CLAIMS

- a. Public work claims of \$375,000 or less between the Contractor and the District are subject to the provisions of Article 1.5 (commencing with §20104) of Chapter 1 of Part 2 of the Public Contract Code (“Article 1.5 claim”). For purposes of Article 1.5, "public work" has the same meaning as set forth in §§3100 and 3106 of the Civil Code; "claims" means a separate demand by Contractor for a time extension or payment of money or damages arising from work done by or on behalf of Contractor pursuant to the Contract and payment of which is not otherwise expressly provided for or the claimant is not otherwise entitled to or the amount of the payment which is disputed by the District.

- b. All claims shall be submitted on or before the date of the Final Payment and shall include all documents necessary to substantiate the claim. District shall respond in writing within 45 days of receipt of claim if the claim is less than or equal to \$50,000 ("\$50,000 claim") or within 60 days if the claim is over \$50,000 but less than or equal to \$375,000 ("50,000 - \$375,000 claim"). In either case, District may request in writing within 30 days of receipt of claim any additional documentation supporting the claim or relating to any defenses to the claim which the District may have against the Contractor. Any additional information shall be requested and provided upon mutual agreement of the District and the Contractor. District's written response to the claim shall be submitted to Contractor within 15 days after receipt of the further documentation for \$50,000 claims or within 30 days after receipt of the further documentation for \$50,000 - \$375,000 claims or within a period of time no greater than that taken by the Contractor in producing the additional information, whichever is greater.
- c. Within 15 days of receipt of the District's response, if Contractor disputes the District's written response, or within 15 days of the District's failure to respond within the time prescribed, the Contractor shall provide written notification to District demanding an informal conference to meet and confer ("conference") to be scheduled by District within 30 days. Following the conference, if any claim or portion remains in dispute, the Contractor may file a claim as provided in Chapter 1 (commencing with §900) and Chapter 2 (commencing with §910) of Part 3 of Division 3.6 of Title 1 of the Government Code. For purposes of those provisions, the period of time within which a claim must be filed is tolled from the time the claimant submits a written claim pursuant to this section until the time that claim is denied as a result of the conference process, including any period of time utilized by the meet and confer process.
- d. Pursuant to Public Contract Code §20104.2(f), this section does not apply to tort claims and does not change the period for filing claims or actions specified by Chapter 1 (commencing with §900) and Chapter 2 (commencing with §910) of Part 3 of Division 3.6 of Title 1 of the Government Code.
- e. If a civil action is filed, within 60 days, but no earlier than 30 days, following the filing of responsive pleadings, the court shall submit the matter to nonbinding mediation unless waived by mutual stipulation of both parties. The mediation process shall provide that both parties select a disinterested third person mediator within 15 days, shall be commenced within 30 days of the submittal, and shall be concluded within 15 days of the commencement of the mediation unless time is extended upon a good cause showing to the court or by stipulation of the parties. If the parties fail to select a mediator within the 15-day period, any party may petition the court to appoint the mediator.
- f. If the matter remains in dispute, the case shall be submitted to judicial arbitration as set forth in Public Contract Code §§20104.4 (b)(1) through (b)(3).
- g. For any claim in excess of \$375,000, the Contractor and the District shall follow the same process as for an Article 1.5 claim. The District will forward a response within 60 days of

submittal of any such claim. Judicial arbitration is not required for claims in excess of \$375,000.

Claims shall also be processed consistent with Public Contract Code section 9204, which provides processing timelines and procedures, and requires that undisputed claims be promptly paid in accordance with this code provision.

- h. In addition, for all unresolved claims that the Contractor wishes to pursue, the Contractor shall file a timely claim pursuant to the Government Claims Act and shall otherwise comply with the procedures set forth in that Act prior to commencing any litigation against the District. The accrual date for any such claim is the date the dispute or controversy first arose regarding the issues raised in the claim.
- i. “The date of Final Payment,” as used in this Article 50, means the date the public entity is required to release retention proceeds in accordance with Public Contract Code §7107 regardless of whether any payment is made to the Contractor at that time.
- j. The claims required by this Article are jurisdictional and conditions precedent to the commencement of any further legal proceedings. Strict compliance with all filing deadlines is mandatory.

51. LABOR COMPLIANCE PROGRAM

If this Contract is for a public works project over \$25,000 or for a maintenance project over \$15,000, Contractor acknowledges that the project is subject to compliance monitoring and enforcement by the California Department of Industrial Relations in accordance with California Labor Code sections 1725.5 and 1770 *et seq.* All bidders, contractors and subcontractors working at the site shall be duly registered with the Department of Industrial Relations at time of bid opening and at all relevant times. Proof of registration shall be provided as to all such contractors prior to the commencement of any work. Contractor shall coordinate with the Architect to ensure that DIR is advised of the award of the construction contract in a timely manner by filing form PWC-100 with DIR within thirty days of award of the contract, but no later than the first day in which the Contractor has workers employed upon the project.

52. DRUG-FREE WORKPLACE CERTIFICATION

Contractor certifies all of the following:

- 1) Contractor is aware of the provisions and requirements of California Government Code §§ 8350 *et seq.*, the Drug Free Workplace Act of 1990.
- 2) Contractor is authorized to certify, and does certify, that a drug free workplace will be provided by doing all of the following:
 - a) Publishing a statement notifying all employees that the unlawful manufacture, distribution, dispensation, possession or use of a controlled substance is prohibited in

Contractor's workplace and specifying actions which will be taken against employees for a violation of the prohibition;

- b) Establishing a drug-free awareness program to inform employees about all of the following:
 - (i) The dangers of drug abuse in the workplace;
 - (ii) Contractor's policy of maintaining a drug-free workplace;
 - (iii) The availability of drug counseling, rehabilitation and employee-assistance programs; and
 - (iv) The penalties that may be imposed upon employees for drug abuse violations;
- c) Requiring that each employee engaged in the performance of Work on the Project be given a copy of the statement required by subdivision (a), above, and that as a condition of employment by Contractor in connection with the Work on the Project, the employee agrees to abide by the terms of the statement.

3) Contractor understands that if the District determines that Contractor has either: (a) made a false certification herein, or (b) violated this certification by failing to carry out and to implement the requirements of Government Code §§ 8350 et seq., the Contract is subject to termination, suspension of payments, or both. Contractor further understands that, should Contractor violate the terms of the Drug-Free Workplace Act of 1990, Contractor may be subject to debarment in accordance with the provisions of Government Code §§ 8350, et seq.

53. PROVISIONS REQUIRED BY LAW DEEMED INSERTED

Every provision of law and clause required by law to be inserted in this Contract shall be deemed to be inserted, and this Contract shall be read and enforced as though it were included, and if through mistake or otherwise any provision is not inserted or is not correctly inserted, upon application of either party the Contract shall be amended to make the insertion or correction. All references to statutes and regulations shall include all amendments, replacements, and enactments on the subject which are in effect as of the date of this Contract.

54. GENERAL PROVISIONS

a. Assignment and Successors:

Neither party may transfer or assign its rights or obligations under the Contract Documents, in part or in whole, without the other party's prior written consent. The Contract Documents are binding on the heirs, successors, and permitted assigns of the parties hereto.

b. Third Party Beneficiaries:

There are no intended third party beneficiaries to the Contract.

c. Choice of Law and Venue

The Contract Documents shall be governed by California law, and venue shall be in the Superior Court of the county in which the project is located, and no other place.

d. Severability

If any provision of the Contract Documents is determined to be illegal, invalid, or unenforceable, in part or in whole, the remaining provisions, or portions of the Contract Documents shall remain in full force and effect.

e. Entire Agreement

The Contract Documents constitute the final, complete, and exclusive statement of the terms of the agreement between the parties regarding the subject matter of the Contract Documents and supersedes all prior written or oral understandings or agreements of the parties.

f. Waiver

No waiver of a breach, failure of any condition, or any right or remedy contained in or granted by the provisions of the Contract Documents shall be effective unless it is in writing and signed by the party waiving the breach, failure, right, or remedy. No waiver of any breach, failure, right, or remedy shall be deemed a waiver of any other breach, failure, right, or remedy, whether or not similar, nor shall any waiver constitute a continuing waiver unless the writing so specifies.

g. Headings

The headings in the Contract Documents are included for convenience only and shall neither affect the construction or interpretation of any provision in the Contract Documents nor affect any of the rights or obligations of the parties to the Contract.

--END--

NOTICE OF AWARD

To:

Project Description: Napa Valley College Wine Education Center.

The District has considered the bid submitted by you for the above described work in response to its Notice Inviting Bids for the Project.

You are hereby notified that your bid has been accepted in the amount of: _____
_____ (\$ _____).

You are required to execute the Contract and furnish the required Performance Bond and Payment Bond using the bond forms provided in the Contract Documents and the required certificates of insurance within ten (10) calendar days from the date of issuance of this Notice.

If you fail to execute the Contract and to furnish the bonds and insurance within ten (10) calendar days from the date of issuance of this Notice, the District will be entitled to consider all your rights arising out of its acceptance of your bid as abandoned and your Bid Bond forfeited. The District will be entitled to such other rights as may be granted by law.

You are required to return an acknowledged copy of this Notice of Award to the District.

Dated this _____ day of _____, 20__.

By _____
Authorized District Signature

Receipt of this above Notice of Award is hereby acknowledged by:

_____, this is the _____
day of _____, 20__.

By _____
Title _____

NOTICE TO PROCEED

To:

Date:

PROJECT: Napa Valley College Wine Education Center.

You are hereby notified to commence work in accordance with the Contract dated _____, 20__, on or before _____, 20__, and you shall complete the work _____ consecutive calendar days thereafter.

By: _____
Authorized District Signature

PERFORMANCE BOND

WHEREAS, the Governing Board of the Napa Valley College District (“District”), at its meeting on _____, 20____, has awarded to _____ (“Principal”), the Contract for performance of the following project (“Project”):
Napa Valley College Wine Education Center.

WHEREAS, the Principal is required under the terms of the Contract to furnish a bond to the District as obligee ensuring its full and faithful performance of the Contract Documents, which are fully incorporated herein by this reference,

NOW, THEREFORE, we, the Principal and _____, as Surety, hereby guarantee the Principal’s full, faithful and complete performance of the Contract Document requirements in the penal sum of _____ dollars (\$ _____) for the payment of which sum will and truly be made, we bind ourselves, our heirs, executors, administrators and successors, jointly, severally, and firmly by this agreement to perform or have performed all of the work and activities required to complete the Project pursuant to the Contract Documents and to pay to the District all damages the District incurs as a result of the Principal’s failure to fully perform in accordance with the Contract Documents.

The condition of the obligation is such that if the Principal, its heirs, executors, administrators, successors or assigns shall in all things abide by, and well and truly keep and perform the covenants, conditions and agreements in the Contract Documents and any amendment thereof made as therein provided, on its or their parts to be kept and performed at the time and in the manner therein specified, and in all respects according to their true intent and meaning, and shall insure and indemnify and save harmless the District, its officers and agents, as therein stipulated, then this obligation shall become null and void. Otherwise, it shall be and remain in full force and effect.

The Surety, for value received, hereby stipulates and agrees that no change, extension of time, alteration or addition to the Contract Documents shall in any way affect its obligations on this bond and it does hereby waive notice of any such change, extension of time, alteration or addition.

Principal and Surety further agree to pay all costs incurred by the District in connection with enforcement of this bond, including, but not limited to the District’s reasonable attorney’s fees and costs incurred, with or without suit, in addition to any other sum required by this bond. Surety further agrees that death, dissolution, or bankruptcy of the Principal shall not relieve the Surety of its obligations hereunder.

In witness whereof, this instrument has been duly executed by the Principal and Surety on the _____ day of _____, 20____.

*To be signed by
Principal and Surety
and acknowledgment
and notarial seal to
be attached.*

PRINCIPAL

By: _____

TITLE _____

SURETY

By: _____

TITLE _____

The above bond is accepted and approved this _____ day of _____, 20__.

By: _____
Authorized District Signature

PAYMENT BOND

WHEREAS, the Napa Valley College District (“District”) and the Contractor, _____ (“Principal”) have entered into a contract (“Contract”) for the furnishing of all materials, labor, services, equipment, tools, supervision and transportation necessary, convenient and proper for the Napa Valley College Wine Education Center project (“Project”) which Contract dated _____, 2____, and all of the Contract Documents made part thereof are fully incorporated herein by this reference; and

WHEREAS, Contractor/Principal is required by Division 4, Part 6, Title 3, Chapter 5 (commencing at Section 9550) of the California Civil Code to furnish a bond in connection with the contract;

NOW, THEREFORE, we, the Contractor/Principal and _____ as Surety, are held firmly bound unto Owner in the penal sum of \$_____ Dollars (\$_____), lawful money of the United States of America for the payment of which sum well and truly to be made, we bind ourselves, our heirs, executors, administrators, successors, and assigns, jointly and severally, firmly by these presents.

THE CONDITION OF THIS OBLIGATION IS SUCH that if the Contractor/Principal, his/her or its heirs, executors, administrators, successors, or assigns, or a subcontractor, shall fail to pay any person or persons named in Civil Code Section 9100 or fail to pay for any materials or other supplies used in, upon, for, or about the performance of the work contracted to be done, or for any work or labor thereon of any kind, or for amounts due under the Unemployment Insurance Code with respect to work or labor thereon of any kind, or shall fail to deduct, withhold, and pay over to the Employment Development Department any amounts required to be deducted, withheld, and paid over by Section 13020 of the Unemployment Insurance Code with respect to work and labor thereon of any kind, then said Surety will pay for the same, in or to an amount not exceeding the amount set forth above, and in case suit is brought upon this bond Surety will also pay such reasonable attorney's fees as shall be fixed by the court, awarded and taxed as provided in Division 4, Part 6, Title 3, Chapter 5 (commencing at Section 9550) of the California Civil Code.

This bond shall inure to the benefit of any of the persons named in Section 9100 of the California Civil Code so as to give a right of action to such person or their assigns in any suit brought upon this bond.

It is further stipulated and agreed that the Surety of this bond shall not be exonerated or released from the obligation of the bond by any change, extension of time for performance, addition, alteration, or modification in, to, or of any contract, plans, specifications, or agreement pertaining or relating to any scheme or work of improvement described above or pertaining or relating to the furnishing of labor, materials, or equipment therefor, nor by any change or modification of any terms of payment or extension of the time for any payment pertaining or relating to any scheme or work of improvement described above, nor by any rescission or attempted rescission of the contract, agreement, or bond, nor by any conditions precedent or subsequent in the bond attempting to limit the right of recovery of claimants otherwise entitled to recover under any such contract or agreement or under the bond, nor by any fraud practiced by any person other than the claimant seeking to recover on the bond, and that this bond be construed most strongly against the Surety and in favor of all persons for whose benefit such bond is given, and under no circumstances shall Surety be released from liability to those for whose benefit such bond has been given, by reason of any breach of contract between the Owner and original contractor or on the part of any obligee named in such

bond, but the sole conditions of recovery shall be that claimant is a person described in Section 8400 and 8402 of the California Civil Code and has not been paid the full amount of his/her or its claim and that Surety does hereby waive notice of any such change, extension of time, addition, alteration, or modification.

In witness whereof, this instrument has been duly executed by the Principal and Surety this _____ day of _____, 20__.

*To be signed by
Principal and Surety
and acknowledgment
and notarial seal to
be attached.*

PRINCIPAL

By:

Title

SURETY

By:

Title

The above bond is accepted and approved this ____ day of _____, 20__.

By: _____
Authorized District Signature

SUPPLEMENTAL CONDITIONS

1. **DIVISION 01 SPECIFICATION SECTIONS:**

Division 01 Sections of the Technical Specifications further defines the intent of the General Conditions and Supplemental Conditions, and specifies additional requirements including, but not limited to, general requirements; scope of work and special project procedures; contract modifications and payment procedures; project management and coordination; construction progress documentation; product submittal and substitution requirements and procedures; quality assurance and control; references and definitions; temporary facilities, utilities, controls and temporary signage; execution, cutting and patching and demolition; closeout procedures; project record documentation; operation and maintenance documentation; and demonstration and training requirements..

2. **AGREEMENT:**

The form of agreement which the successful bidder, as contractor, will be required to execute is included in the contract documents and should be carefully examined by the Bidder. The agreement and bonds shall be executed in two (2) original counterparts.

3. **TIME FOR COMPLETION:**

The starting date of the Contract shall be the day listed by the District in the Notice to Proceed.

Expected Project Schedule:

Notice of Award:	May 16, 2024
Notice to Proceed:	May 17, 2024
Construction completion:	May 2, 2025

4. **LIQUIDATED DAMAGES:**

Time is of the essence in the performance of this Contract. Liquidated damages for Contractor's failure to complete the milestones and the Contract within the times fixed are established in the amounts of:

<u>DESCRIPTION OF MILESTONE</u>	<u>DATE OF MILESTONE</u>	<u>LIQUIDATED DAMAGES PER CALENDAR DAY FOR LATE COMPLETION</u>
a. Completion of work	May 2, 2025	\$1,000.00

5. **SCHEDULE CONSTRAINTS**

To minimize disruption to critical education activities, Contractor shall accommodate for the following schedule constraints, in addition to the Completion Date set forth in the Contract.

- a. Campus openings and first week of fall, spring, and summer sessions.
- b. Housing move-ins and students returning to campus.
- c. Early Learning Center – Pick Up / Drop Off hours.

- d. Contractor will need to coordinate their work and their calendar with the NVC events and academic calendar. This is an ongoing task.
- e. Normal construction hours are between 6:00 am and 5:30 pm.

6. CONTRACT SETS OF CONTRACT DOCUMENTS

The Architect will provide the Contractor access to digital files located on a web-based project information management system. Printed sets will not be provided.

7. PUBLIC LIABILITY INSURANCE

General Conditions, Article 11 "Insurance," Section 11.c. shall be revised to include the Construction Manager, Architect, and the Project Inspector as additional insured on the Public Liability Insurance Policy.

8. INDEMNITY

General Conditions, Article 29 "Indemnity," after the words "Construction Manager" add the words "Project Inspector,"

9. WARRANTY OF SUPPLIES, EQUIPMENT AND RELATED ADDITIONAL SERVICES

If the Contractor fails to carry out the responsibilities described in the General Conditions, Article 32, "Guarantee and Warranty" then the Contractor will also be solely responsible for the costs and charges incurred by the District's Construction Managers, Architects, Engineers, Consultants and other representatives by failure to repair defects within the allotted time after receipt of written notification by the District.

10. SUBMITTALS

General Conditions, Article 26 "Submittals: Shop Drawings, Cuts and Samples;" Revise the quantity of shop drawings, brochures, and catalog cuts, to be submitted to be three (3).

11. MEANING OF TERMS

Terms indicated that have common and well-known technical or trade meanings, unless specifically defined otherwise in the Contract Documents, shall be interpreted in accordance with their common and well-known meanings.

12. FINAL COMPLETION

"Final Completion" shall be substituted for the term "Substantial Completion" as it occurs in the technical specifications.

13. ABNORMAL WEATHER CONDITIONS

If adverse weather conditions are the basis for a Claim for additional time, such Claim shall be documented by data substantiating the weather conditions were abnormal for the period of time and could not have been reasonably anticipated, and that the weather conditions had an adverse effect on the critical path of the scheduled construction. A rain, windstorm, high water, or other natural phenomenon of the specific locality of the Work, which might reasonably be anticipated from historical records of the general locality of the Work, shall not be construed as abnormal. It is hereby agreed that rainfall greater than the following, when impacting activities on the critical path, cannot be reasonably anticipated:

- a. Daily rainfall equal to, or greater than, 1 inch during a month when the monthly rainfall exceeds the normal monthly average by 15% or more.

- b. Daily rainfall equal to, or greater than, the 5-year storm, 24-hour duration at any time.
- c. Source of Weather Information: Western Regional Weather Center:
<http://www.wrcc.dri.edu/summary/climsmnca.html>
- d. Project Location: Napa, California

END OF SUPPLEMENTAL CONDITIONS

THIS PAGE INTENTIONALLY LEFT BLANK

SECTION 00 31 19

EXISTING CONDITION INFORMATION

1.1 EXISTING CONDITION INFORMATION

- A. This Document with its referenced attachments is part of the Procurement and Contracting Requirements for Project. They provide Owner's information for Bidders' convenience and are intended to supplement rather than serve in lieu of the Bidders' own investigations. They are made available for Bidders' convenience and information, but are not a warranty of existing conditions. This Document and its attachments are not part of the Contract Documents.
- B. Existing drawings that include information on existing conditions including previous construction at Project site are available for viewing on Project Web site.
- C. Related Requirements:
1. Document "Construction Bid Documents (CCD)" for the Bidder's responsibilities for examination of Project site and existing conditions.
 - a. Modular Building Pans for Napa Valley College Wine Lab. DSA File #28-C1, DSA Application #01-101639; DSA approval date June 23, 1999.
 - b. Napa Valley Vintners Teaching Winery. DSA File #28-C1, DSA Application #01-103886, DSA approval date September 20, 2001.
 - c. Napa Valley College Wine Storage Building. Non-DSA project. Prepared by TLCD Architecture, Project #05067.00; dated January 10, 2007.
 - 1) Addendum No. One, dated March 28, 2007. Prepared by TLCD Architecture.
 - 2) Cost Request No. 1, dated May 7, 2007. Prepared by TLCD Architecture.
 2. Owners existing hazardous material information for hazardous materials reports that are made available to bidders by the Owner.
 - a. Demolition Asbestos/Lead Survey for Napa Valley College at Building 3220 Ag-Lab located on the Napa Valley College Campus in Napa California." Prepared by FIT Environmental Services; Project #24-017, dated February 29, 2024.
 - b. Demolition Asbestos/Lead Survey for Napa Valley College at Building 3200 located on the Napa Valley College Campus in Napa California." Prepared by FIT Environmental Services; Project #24-018, dated February 29, 2024.
 3. Document 00 31 32 "Geotechnical Data" for reports and soil-boring data from geotechnical and geological hazard investigations that are made available to bidders.

END OF SECTION

THIS PAGE LEFT INTENTIONALLY BLANK

SECTION 00 31 32 – GEOTECHNICAL DATA

1.1 SUMMARY

- A. The geotechnical data was prepared from the Owner's subsurface exploration and geotechnical evaluation includes location plan, exploration results, borings, general notes, and soil classification system.
1. A geotechnical investigation has been conducted for the Project site by the Owner's Geotechnical Engineering Consultant, independent of the Architect, to reasonably determine existing site conditions. The Owner's Geotechnical Engineering Consultant has prepared a Geotechnical Investigation Report (Soils Report) to provide recommendations to the design professionals, and provide requirements for construction of the Project by the Contractor.
 - a. Owner's Geotechnical Consultant:
 - 1) Name: Signet Testing Laboratories, Inc.
 - 2) Address: 3526 Breakwater Court, Hayward, California 94545
 - 3) Phone: (510) 887-8484.
 - b. Title of Report: "Geological Engineering Investigation for Proposed Wine Education Complex, Napa Valley College, Napa, CA."
 - c. Date of Report: August 5, 2022.
 - d. Geotechnical Firm's Project Number: 2407-40.
 2. The Owner's Soils Report is available from the Owner.
 3. A geological hazard study has been conducted for the Project site by the Owner's Geotechnical Engineering Consultant, independent of the Architect, to reasonably determine existing site conditions. The Owner's Geological Engineering Consultant has prepared a Geological Hazard Study to provide recommendations to the design professionals, and provide requirements for construction of the Project by the Contractor.
 - a. Owner's Geological Engineering Consultant:
 - 1) Name: Allerion Consulting Group, Inc.
 - 2) Address: 1050 Melody Lane, Suite 160, Roseville, California 95678
 - 3) Phone: (510) 887-8484.
 - b. Title of Report: "Geological Hazard Study, Proposed Wine Napa Valley College Viticultural Teaching Winery, Napa, California."
 - c. Date of Report: August 5, 2022.
 - d. Geotechnical Firm's Project Number: 05-22040G.
 4. The Owner's Geological Hazard Study is available from the Owner.
 5. Prior to bidding, bidders may make their own subsurface investigations to satisfy themselves as to site and subsurface conditions. Such investigations may be performed only under time schedules and arrangements approved in advance by the Owner.
 - a. Costs for Contractor's site investigations are solely the responsibility of the Contractor, including repairs for damages to existing surfaces.
- B. Data on indicated subsurface conditions provided by the Owner are not intended as representations or warranties of continuity of such conditions. It is expressly understood that the Owner is not responsible for interpretations or conclusions drawn from the data by the Contractor. Data are made available for the convenience of the Contractor and are not guaranteed to represent conditions that may be encountered.
1. The reports identify properties of below grade conditions and offers recommendations for the design of foundations, paving and other construction components primarily for the use of the Architect and Engineers.
-

2. The recommendations described shall not be construed as a requirement of the Contract unless specifically referenced in the Contract Documents.
3. The report, by its nature, cannot reveal all conditions existing on the site. Should subsurface conditions be found to vary substantially from this report, changes in the design and construction of foundations, paving and other construction components will be made with resulting credits or additions to the Contract sum accruing to the Owner.

PART 2 - PRODUCTS (Not Used)

PART 3 - EXECUTION (Not Used)

END OF SECTION

NAPA VALLEY COLLEGE WINE EDUCATION CENTER

2277 NAPA VALLEJO HWY NAPA, CA 94558

DSA Application # 01-120890 File # 28-C1

ABBREVIATIONS

CCF1 - CONTRACTOR FURNISH	FLR - FLOOR	PAVT - PAVEMENT
CCF2 - CONTRACTOR INSTALL	FRM - FIRE FRAMING	QT - QUARRY TILE
CCF3 - CONTRACTOR FURNISH	FRN - FRIEZE	RAD - RAIL
CCF4 - CONTRACTOR FURNISH	FRS - FLOOR FINISH	RAH - ROOF ACCESS HATCH
CCF5 - CONTRACTOR FURNISH	FRS - FLOOR FINISH	RAI - ROOF ACCESS
CCF6 - CONTRACTOR FURNISH	FRS - FLOOR FINISH	RCP - REFLECTED CEILING PLAN
CCF7 - CONTRACTOR FURNISH	FRS - FLOOR FINISH	RDF - ROOF DRAIN
CCF8 - CONTRACTOR FURNISH	FRS - FLOOR FINISH	RFD - ROOF DRAIN
CCF9 - CONTRACTOR FURNISH	FRS - FLOOR FINISH	RFD - ROOF DRAIN
CCF10 - CONTRACTOR FURNISH	FRS - FLOOR FINISH	RFD - ROOF DRAIN
CCF11 - CONTRACTOR FURNISH	FRS - FLOOR FINISH	RFD - ROOF DRAIN
CCF12 - CONTRACTOR FURNISH	FRS - FLOOR FINISH	RFD - ROOF DRAIN
CCF13 - CONTRACTOR FURNISH	FRS - FLOOR FINISH	RFD - ROOF DRAIN
CCF14 - CONTRACTOR FURNISH	FRS - FLOOR FINISH	RFD - ROOF DRAIN
CCF15 - CONTRACTOR FURNISH	FRS - FLOOR FINISH	RFD - ROOF DRAIN
CCF16 - CONTRACTOR FURNISH	FRS - FLOOR FINISH	RFD - ROOF DRAIN
CCF17 - CONTRACTOR FURNISH	FRS - FLOOR FINISH	RFD - ROOF DRAIN
CCF18 - CONTRACTOR FURNISH	FRS - FLOOR FINISH	RFD - ROOF DRAIN
CCF19 - CONTRACTOR FURNISH	FRS - FLOOR FINISH	RFD - ROOF DRAIN
CCF20 - CONTRACTOR FURNISH	FRS - FLOOR FINISH	RFD - ROOF DRAIN
CCF21 - CONTRACTOR FURNISH	FRS - FLOOR FINISH	RFD - ROOF DRAIN
CCF22 - CONTRACTOR FURNISH	FRS - FLOOR FINISH	RFD - ROOF DRAIN
CCF23 - CONTRACTOR FURNISH	FRS - FLOOR FINISH	RFD - ROOF DRAIN
CCF24 - CONTRACTOR FURNISH	FRS - FLOOR FINISH	RFD - ROOF DRAIN
CCF25 - CONTRACTOR FURNISH	FRS - FLOOR FINISH	RFD - ROOF DRAIN
CCF26 - CONTRACTOR FURNISH	FRS - FLOOR FINISH	RFD - ROOF DRAIN
CCF27 - CONTRACTOR FURNISH	FRS - FLOOR FINISH	RFD - ROOF DRAIN
CCF28 - CONTRACTOR FURNISH	FRS - FLOOR FINISH	RFD - ROOF DRAIN
CCF29 - CONTRACTOR FURNISH	FRS - FLOOR FINISH	RFD - ROOF DRAIN
CCF30 - CONTRACTOR FURNISH	FRS - FLOOR FINISH	RFD - ROOF DRAIN
CCF31 - CONTRACTOR FURNISH	FRS - FLOOR FINISH	RFD - ROOF DRAIN
CCF32 - CONTRACTOR FURNISH	FRS - FLOOR FINISH	RFD - ROOF DRAIN
CCF33 - CONTRACTOR FURNISH	FRS - FLOOR FINISH	RFD - ROOF DRAIN
CCF34 - CONTRACTOR FURNISH	FRS - FLOOR FINISH	RFD - ROOF DRAIN
CCF35 - CONTRACTOR FURNISH	FRS - FLOOR FINISH	RFD - ROOF DRAIN
CCF36 - CONTRACTOR FURNISH	FRS - FLOOR FINISH	RFD - ROOF DRAIN
CCF37 - CONTRACTOR FURNISH	FRS - FLOOR FINISH	RFD - ROOF DRAIN
CCF38 - CONTRACTOR FURNISH	FRS - FLOOR FINISH	RFD - ROOF DRAIN
CCF39 - CONTRACTOR FURNISH	FRS - FLOOR FINISH	RFD - ROOF DRAIN
CCF40 - CONTRACTOR FURNISH	FRS - FLOOR FINISH	RFD - ROOF DRAIN
CCF41 - CONTRACTOR FURNISH	FRS - FLOOR FINISH	RFD - ROOF DRAIN
CCF42 - CONTRACTOR FURNISH	FRS - FLOOR FINISH	RFD - ROOF DRAIN
CCF43 - CONTRACTOR FURNISH	FRS - FLOOR FINISH	RFD - ROOF DRAIN
CCF44 - CONTRACTOR FURNISH	FRS - FLOOR FINISH	RFD - ROOF DRAIN
CCF45 - CONTRACTOR FURNISH	FRS - FLOOR FINISH	RFD - ROOF DRAIN
CCF46 - CONTRACTOR FURNISH	FRS - FLOOR FINISH	RFD - ROOF DRAIN
CCF47 - CONTRACTOR FURNISH	FRS - FLOOR FINISH	RFD - ROOF DRAIN
CCF48 - CONTRACTOR FURNISH	FRS - FLOOR FINISH	RFD - ROOF DRAIN
CCF49 - CONTRACTOR FURNISH	FRS - FLOOR FINISH	RFD - ROOF DRAIN
CCF50 - CONTRACTOR FURNISH	FRS - FLOOR FINISH	RFD - ROOF DRAIN
CCF51 - CONTRACTOR FURNISH	FRS - FLOOR FINISH	RFD - ROOF DRAIN
CCF52 - CONTRACTOR FURNISH	FRS - FLOOR FINISH	RFD - ROOF DRAIN
CCF53 - CONTRACTOR FURNISH	FRS - FLOOR FINISH	RFD - ROOF DRAIN
CCF54 - CONTRACTOR FURNISH	FRS - FLOOR FINISH	RFD - ROOF DRAIN
CCF55 - CONTRACTOR FURNISH	FRS - FLOOR FINISH	RFD - ROOF DRAIN
CCF56 - CONTRACTOR FURNISH	FRS - FLOOR FINISH	RFD - ROOF DRAIN
CCF57 - CONTRACTOR FURNISH	FRS - FLOOR FINISH	RFD - ROOF DRAIN
CCF58 - CONTRACTOR FURNISH	FRS - FLOOR FINISH	RFD - ROOF DRAIN
CCF59 - CONTRACTOR FURNISH	FRS - FLOOR FINISH	RFD - ROOF DRAIN
CCF60 - CONTRACTOR FURNISH	FRS - FLOOR FINISH	RFD - ROOF DRAIN
CCF61 - CONTRACTOR FURNISH	FRS - FLOOR FINISH	RFD - ROOF DRAIN
CCF62 - CONTRACTOR FURNISH	FRS - FLOOR FINISH	RFD - ROOF DRAIN
CCF63 - CONTRACTOR FURNISH	FRS - FLOOR FINISH	RFD - ROOF DRAIN
CCF64 - CONTRACTOR FURNISH	FRS - FLOOR FINISH	RFD - ROOF DRAIN
CCF65 - CONTRACTOR FURNISH	FRS - FLOOR FINISH	RFD - ROOF DRAIN
CCF66 - CONTRACTOR FURNISH	FRS - FLOOR FINISH	RFD - ROOF DRAIN
CCF67 - CONTRACTOR FURNISH	FRS - FLOOR FINISH	RFD - ROOF DRAIN
CCF68 - CONTRACTOR FURNISH	FRS - FLOOR FINISH	RFD - ROOF DRAIN
CCF69 - CONTRACTOR FURNISH	FRS - FLOOR FINISH	RFD - ROOF DRAIN
CCF70 - CONTRACTOR FURNISH	FRS - FLOOR FINISH	RFD - ROOF DRAIN
CCF71 - CONTRACTOR FURNISH	FRS - FLOOR FINISH	RFD - ROOF DRAIN
CCF72 - CONTRACTOR FURNISH	FRS - FLOOR FINISH	RFD - ROOF DRAIN
CCF73 - CONTRACTOR FURNISH	FRS - FLOOR FINISH	RFD - ROOF DRAIN
CCF74 - CONTRACTOR FURNISH	FRS - FLOOR FINISH	RFD - ROOF DRAIN
CCF75 - CONTRACTOR FURNISH	FRS - FLOOR FINISH	RFD - ROOF DRAIN
CCF76 - CONTRACTOR FURNISH	FRS - FLOOR FINISH	RFD - ROOF DRAIN
CCF77 - CONTRACTOR FURNISH	FRS - FLOOR FINISH	RFD - ROOF DRAIN
CCF78 - CONTRACTOR FURNISH	FRS - FLOOR FINISH	RFD - ROOF DRAIN
CCF79 - CONTRACTOR FURNISH	FRS - FLOOR FINISH	RFD - ROOF DRAIN
CCF80 - CONTRACTOR FURNISH	FRS - FLOOR FINISH	RFD - ROOF DRAIN
CCF81 - CONTRACTOR FURNISH	FRS - FLOOR FINISH	RFD - ROOF DRAIN
CCF82 - CONTRACTOR FURNISH	FRS - FLOOR FINISH	RFD - ROOF DRAIN
CCF83 - CONTRACTOR FURNISH	FRS - FLOOR FINISH	RFD - ROOF DRAIN
CCF84 - CONTRACTOR FURNISH	FRS - FLOOR FINISH	RFD - ROOF DRAIN
CCF85 - CONTRACTOR FURNISH	FRS - FLOOR FINISH	RFD - ROOF DRAIN
CCF86 - CONTRACTOR FURNISH	FRS - FLOOR FINISH	RFD - ROOF DRAIN
CCF87 - CONTRACTOR FURNISH	FRS - FLOOR FINISH	RFD - ROOF DRAIN
CCF88 - CONTRACTOR FURNISH	FRS - FLOOR FINISH	RFD - ROOF DRAIN
CCF89 - CONTRACTOR FURNISH	FRS - FLOOR FINISH	RFD - ROOF DRAIN
CCF90 - CONTRACTOR FURNISH	FRS - FLOOR FINISH	RFD - ROOF DRAIN
CCF91 - CONTRACTOR FURNISH	FRS - FLOOR FINISH	RFD - ROOF DRAIN
CCF92 - CONTRACTOR FURNISH	FRS - FLOOR FINISH	RFD - ROOF DRAIN
CCF93 - CONTRACTOR FURNISH	FRS - FLOOR FINISH	RFD - ROOF DRAIN
CCF94 - CONTRACTOR FURNISH	FRS - FLOOR FINISH	RFD - ROOF DRAIN
CCF95 - CONTRACTOR FURNISH	FRS - FLOOR FINISH	RFD - ROOF DRAIN
CCF96 - CONTRACTOR FURNISH	FRS - FLOOR FINISH	RFD - ROOF DRAIN
CCF97 - CONTRACTOR FURNISH	FRS - FLOOR FINISH	RFD - ROOF DRAIN
CCF98 - CONTRACTOR FURNISH	FRS - FLOOR FINISH	RFD - ROOF DRAIN
CCF99 - CONTRACTOR FURNISH	FRS - FLOOR FINISH	RFD - ROOF DRAIN
CCF100 - CONTRACTOR FURNISH	FRS - FLOOR FINISH	RFD - ROOF DRAIN

SYMBOLS

	GRID LINE INDICATION
	FACE OF CENTER OF
	ROOM IDENTIFICATION
	ROOM NAME
	ROOM NUMBER
	FURNITURE / EQUIPMENT IDENTIFICATION
	FURNITURE / EQUIPMENT CODE
	KEYNOTE & DRAWING NOTE IDENTIFICATION
	REFERENCE KEYNOTE - SEE SCHEDULE ON SHEETS & SPECIFICATIONS
	DRAWING NOTE - SEE SCHEDULE ON SHEETS
	ELEVATION
	ELEVATION VIEW NUMBER
	ELEVATION SHEET
	SECTION
	SECTION NUMBER
	SECTION SHEET
	DETAIL
	DETAIL NUMBER
	DETAIL SHEET
	DOOR NUMBER
	BY ROOM NUMBER - REFER TO DOOR SCHEDULE
	PARTITION TYPE INDICATOR
	REFER TO PARTITION LEGEND
	WORK POINT
	(CONTROL OF DATUM POINT)
	FINISH INDICATOR
	FINISH CODE
	STOREFRONT / CURTAIN WALL TYPE INDICATOR
	REFER TO STOREFRONT / CURTAIN WALL TYPES
	DIMENSIONS
	STANDARD DIMENSION - FACE OF STUD WHERE APPLIED TO WALLS OR PARTITIONS, UNO
	FINISH TO FINISH DIMENSION - FACE OF GYP. OR DIMENSIONAL FINISH WHERE APPLIED TO WALLS OR PARTITIONS, UNO
	INCHES
	FEET
	PERCENT
	AND
	PLUS OR MINUS
	NUMBER
	AT
	GREATER THAN
	LESS THAN
	DIAMETER
	DEGREE
	ANGLE
	CENTERLINE
	PROPERTY LINE
	FLOOR LINE

APPLICABLE CODES

BUILDING CODES AND STANDARDS as of January 1, 2023*

2022 CALIFORNIA ADMINISTRATIVE CODE (CAC), PART 1, TITLE 24 CCR
(2021 INTERNATIONAL BUILDING CODE, VOLUMES 1 & 2, AND 2022 CALIFORNIA AMENDMENTS)

2022 CALIFORNIA BUILDING CODE (CBC), PART 2, TITLE 24 CCR
(2021 INTERNATIONAL BUILDING CODE, VOLUMES 1 & 2, AND 2022 CALIFORNIA AMENDMENTS)

2022 CALIFORNIA ELECTRICAL CODE (CEC), PART 3, TITLE 24 CCR
(2020 NATIONAL ELECTRICAL CODE AND 2022 CALIFORNIA AMENDMENTS)

2022 CALIFORNIA MECHANICAL CODE (CMC), PART 4, TITLE 24 CCR
(2021 IAPMO UNIFORM MECHANICAL CODE AND 2022 CALIFORNIA AMENDMENTS)

2022 CALIFORNIA PLUMBING CODE (CPC), PART 5, TITLE 24 CCR
(2021 IAPMO UNIFORM PLUMBING CODE AND 2022 CALIFORNIA AMENDMENTS)

2022 CALIFORNIA ENERGY CODE (CEC), PART 6, TITLE 24 CCR

2022 CALIFORNIA FIRE CODE (CFC), PART 9, TITLE 24 CCR
(2021 INTERNATIONAL FIRE CODE AND 2022 CALIFORNIA AMENDMENTS)

2022 CALIFORNIA GREEN BUILDING STANDARDS CODE (CALGreen), PART 11, TITLE 24 CCR

2022 CALIFORNIA REFERENCE STANDARDS CODE, PART 12, TITLE 24 CCR

TITLE 19 CCR, PUBLIC SAFETY, STATE FIRE MARSHAL REGULATIONS

NATIONAL REFERENCE STANDARDS

ASCE 341-16 - SEISMIC PROVISIONS FOR STRUCTURAL STEEL BUILDINGS

AISC 358-16 - PREQUALIFIED CONNECTIONS STANDARD

AISC 360-16 - SPECIFICATION FOR STRUCTURAL STEEL BUILDINGS

ANSI/APWC NDS-2018 - NATIONAL DESIGN SPECIFICATION FOR WOOD CONSTRUCTION WITH 2018 NDS SUPPLEMENTS

SDPWS 2021 - SPECIAL DESIGN PROVISIONS FOR WIND AND SEISMIC WITH COMMENTARY

ACI-318-19 - BUILDING CODE REQUIREMENTS FOR STRUCTURAL CONCRETE

ASCE 7-16 - MINIMUM DESIGN LOADS AND ASSOCIATED CRITERIA FOR BUILDINGS AND OTHER STRUCTURES (WITH SUPPLEMENT NO. 1, 2, AND 3)

NFPA 04-21 - STANDARD FOR INTEGRATED FIRE PROTECTION AND LIFE SAFETY SYSTEM TESTING

NFPA 10-21 - STANDARD FOR PORTABLE FIRE EXTINGUISHERS

NFPA 13-22 - STANDARD FOR THE INSTALLATION OF FIRE SPRINKLERS (CA AMENDED)

NFPA 14-19 - STANDARD FOR THE INSTALLATION OF STANDPIPE AND HOSE SYSTEMS (CA AMENDED)

NFPA 17-21 - STANDARD FOR DRY CHEMICAL EXTINGUISHING SYSTEMS

NFPA 17A-21 - STANDARD FOR WET CHEMICAL EXTINGUISHING SYSTEMS

NFPA 20-19 - STANDARD FOR THE INSTALLATION OF STATIONARY PUMPS FOR FIRE PROTECTION

NFPA 24-19 - STANDARD FOR THE INSTALLATION OF PRIVATE FIRE SERVICE MAINS AND THEIR APPURTENANCES (CA AMENDED)

NFPA 25-13CA - CALIFORNIA NFPA 25 EDITION (BASED ON THE 2011 EDITION) INSPECTION, TESTING, AND MAINTENANCE OF WATER-BASED FIRE PROTECTION SYSTEMS

NFPA 70-20 - NATIONAL ELECTRICAL CODE

NFPA 72-22 - NATIONAL FIRE ALARM AND SIGNALING CODE (CA AMENDED)

NFPA 80-19 - STANDARD FOR FIRE DOORS AND OTHER OPENING PROTECTIVES

NFPA 92-18 - STANDARD FOR SMOKE CONTROL SYSTEMS

NFPA 101-21 - LIFE SAFETY CODE

NFPA 105-19 - STANDARD FOR SMOKE DOOR ASSEMBLIES AND OTHER OPENING PROTECTIVES

NFPA 110-19 - STANDARD FOR EMERGENCY AND STANDBY POWER SYSTEMS

NFPA 2001-18 - STANDARD ON CLEAN AGENT FIRE EXTINGUISHING SYSTEMS (CA AMENDED)

UL 464-03 - AUDIBLE SIGNALING APPLIANCES - WITH REVISIONS THROUGH OCT 10, 2003

UL 521-09 - HEAT DETECTORS FOR FIRE PROTECTIVE SIGNALING SYSTEMS - WITH REVISIONS THROUGH JULY 20, 2005

UL 1971 - STANDARD FOR SIGNALING DEVICES FOR THE HEARING IMPAIRED - 2002 (R2010)

ADA (AMERICANS WITH DISABILITIES ACT, 1990) 2010 EDITION

ADA STANDARDS FOR ACCESSIBLE DESIGN (APPENDIX A OF 28 CFR PART 36)

PROJECT NOTES

2022 CALIFORNIA CODE OF REGULATIONS (CCR), TITLE 24, PART 1 ADMINISTRATIVE CODE REQUIREMENTS, CHAPTER 4 (PARTIAL LISTING ONLY)

- A COPY OF CALIFORNIA CODE OF REGULATIONS, TITLE 24, PARTS 1 THROUGH 5, SHALL BE KEPT ON THE JOB SITE AT ALL TIMES.
- ALL CONSTRUCTION CHANGE DOCUMENTS AND ADDENDA TO BE SIGNED BY THE ARCHITECT, STRUCTURAL ENGINEER (WHEN APPLICABLE), DELEGATED PROFESSIONAL ENGINEER, AND OWNER AND APPROVED BY DSA BEFORE PROCEEDING WITH THE WORK, CCR, TITLE 24, PART 1, SECTION 4-338 AND DSA IR 4-6.
- ALL TESTS TO CONFORM TO THE REQUIREMENTS OF CCR, TITLE 24, PART 1, SECTION 4-335 AND APPROVED FORM DSA 103 *LIST OF REQUIRED STRUCTURAL INSPECTIONS AND SPECIAL INSPECTIONS.
- TESTS OF MATERIALS AND TESTING LABORATORY SHALL BE IN ACCORDANCE WITH CCR, TITLE 24, PART 1, SECTION 4-335 AND SHALL BE APPROVED BY THE LABORATORY. COSTS OF RE-TEST MAY BE BACK CHARGED TO THE CONTRACTOR, SEE SPECIFICATIONS.
- DSA SHALL BE NOTIFIED AT THE START OF CONSTRUCTION AND PRIOR TO THE REPLACEMENT OF CONCRETE PER CCR, TITLE 24, PART 1, SECTION 4-331.
- A DSA "CERTIFIED" PROJECT INSPECTOR SHALL BE APPROVED BY DSA AND EMPLOYED BY THE OWNER. INSPECTION SHALL BE IN ACCORDANCE WITH CCR, TITLE 24, PART 1, SECTIONS 4-333(i) AND 4-342.
- SUPERVISION OF CONSTRUCTION BY DSA SHALL BE IN ACCORDANCE WITH CCR, TITLE 24, PART 1, SECTION 4-334.
- CONTRACTOR, INSPECTOR, ARCHITECT, AND ENGINEERS SHALL SUBMIT VERIFIED REPORTS IN ACCORDANCE WITH CCR, TITLE 24, PART 1, SECTIONS 4-336 AND 4-343.
- THE ARCHITECT AND THE STRUCTURAL ENGINEER SHALL PERFORM THEIR DUTIES IN ACCORDANCE WITH CCR, TITLE 24, PART 1, SECTIONS 4-333(i) AND 4-341.
- THE CONTRACTOR SHALL PERFORM HIS DUTIES IN ACCORDANCE WITH CCR, TITLE 24, PART 1, SECTION 4-343.

SUMMARY OF WORK

DEMOLITION OF TWO EXISTING BUILDINGS (ONE MODULAR, ONE WOOD FRAMED), AND THE CONSTRUCTION OF A NEW BUILDING AND ASSOCIATED SITE WORK INCLUDING A NEW FIRE HAZARD ANALYSIS.

OCCUPANCY: A-3, A-2, B (A OCCUPANCY GOVERNING)

CONSTRUCTION: Type VB

SPRINKLERS: YES

APPROX. 7,812 SQ. FT.

PROJECT TEAM

OWNER
NAPA VALLEY COLLEGE
2277 NAPA VALLEJO HWY
NAPA, CA 94558
PHONE: 707.256.7584
CONTACT: SAMANTHA MADDOX

CIVIL ENGINEER
BRELLIE & RACE CONSULTING ENGINEERS
475 AVIATION COULEVARD, SUITE 120
SANTA ROSA, CA 95403
PHONE: 707.538.3731
CONTACT: RYAN D. GLEASON

MECHANICAL ENGINEER
TEP ENGINEERS
880 SECOND STREET
SANTA ROSA, CA 95404-4610
PHONE: 707.538.4265
CONTACT: TIM SOUZA

ENERGY
SOLDATA ENERGY CONSULTING, INC
2227 CAPRICORN WAY, SUITE 202
SANTA ROSA, CA 95407
PHONE: 707.545.4440
CONTACT: SEAN FLUKHIN

AUDIO-VISUAL
SALTER
130 SUTTER STREET, FLOOR 5
SAN FRANCISCO, CA 94104
PHONE: 415.471.3658
CONTACT: KEVIN GRAVER

ARCHITECT
TLCD ARCHITECTURE
520 THIRD ST., SUITE #250
SANTA ROSA, CA 95401
PHONE: 707.526.0992
CONTACT: CARL SERVAIS

STRUCTURAL ENGINEER
ZFA STRUCTURAL ENGINEERS
1212 FOURTH ST., SUITE Z
SANTA ROSA, CA 95404
PHONE: 707.538.3731
CONTACT: CHRIS WARNER

ELECTRICAL ENGINEER
OTAMOVY & MYER, INC
4340 REDWOOD HIGHWAY, #245
SAN RAFAEL, CA 94903
PHONE: 415.462.4020
CONTACT: PAUL CAREY

LANDSCAPE ARCHITECT & PLANNING
RHAA LANDSCAPE ARCHITECTURE & PLANNING
225 MILLER AVE
MILL VALLEY, CA 94941
PHONE: 415.383.7800
CONTACT: BARBARA LUNDBERG

DEFERRED APPROVAL ITEMS:

- CURTAIN WALL SYSTEMS
- SLIDING GLASS WALL UNITS

FABRICATION AND INSTALLATION OF DEFERRED SUBMITTAL ITEMS SHALL NOT BE STARTED UNTIL CONTRACTORS DRAWINGS, SPECIFICATIONS, AND ENGINEERING CALCULATIONS FOR THE ACTUAL SYSTEMS TO BE INSTALLED HAVE BEEN ACCEPTED AND SIGNED BY THE ARCHITECT OR STRUCTURAL ENGINEER AND APPROVED BY THE DSA.

SHEET INDEX

GENERAL	TITLE SHEET	ARCHITECTURAL	A-001 PARTIAL SITE PLAN - DEMOLITION WORK	ELECTRICAL	E-001 GENERAL NOTES, LIST OF DRAWINGS
G-001	CAMPUS PLAN - CODE ANALYSIS	A-002	PARTIAL SITE PLAN - PHASE 1	E-002 ELECTRICAL SYMBOLS LIST	E-003 LUMINAIRE SCHEDULE
G-002	BUILDING CODE ANALYSIS	A-103	FLOOR PLAN, ROOF PLAN - PHASE 1	E-101 SITE PLAN ELECTRICAL	E-102 PARTIAL SITE PLAN
G-003	TITLE 24 ENERGY COMPLIANCE	A-121	FLOOR PLAN, ROOF PLAN - PHASE 2	E-103 PARTIAL SITE PLAN - DEMO	E-104 SITE PLAN - LIGHTING
G-004	TITLE 24 ENERGY COMPLIANCE	A-122	EXTERIOR ELEVATIONS	E-201 FLOOR PLAN LIGHTING - PHASE 1	E-202 FLOOR PLAN LIGHTING - PHASE 2
G-005	TITLE 24 ENERGY COMPLIANCE	A-171	EXTERIOR ELEVATIONS	E-301 FLOOR PLAN POWER & SIGNAL - PHASE 1	E-302 FLOOR PLAN POWER & SIGNAL - PHASE 2
G-006	TITLE 24 ENERGY COMPLIANCE	A-251	INTERIOR ELEVATIONS - PHASE 1	E-303 ENLARGED FLOOR PLAN - PHASE 1	E-304 FLOOR PLANS MP CONNECTIONS - PHASE 1
G-007	TITLE 24 ENERGY COMPLIANCE	A-252	INTERIOR ELEVATIONS - PHASE 2	E-305 FLOOR PLANS MP CONNECTIONS - PHASE 2	E-306 RESTROOMS
G-008	TITLE 24 ENERGY COMPLIANCE	A-301	BUILDING & WALL SECTIONS	E-401 DETAILS - ACCESSIBLE	E-402 DETAILS - WALLS AND PARTITIONS
G-009	CALGREEN MANDATORY MEASURES	A-401	ENLARGED FLOOR PLAN AND INTERIOR ELEVATIONS - PHASE 1	E-403 DETAILS - EXTERIOR	E-404 DETAILS - MISC
CIVIL	ABBREVIATIONS, LEGEND & NOTES	A-402	ENLARGED FLOOR PLAN AND INTERIOR ELEVATIONS - PHASE 2	E-405 PLACARDS & DATA SHEETS	E-406 SCHEDULES
C-001	PHASE 1 DEMOLITION PLAN	C-100	PHASE 2 GRADING PLAN	E-407 DETAILS	E-408 DETAILS
C-100	PHASE 2 GRADING PLAN	C-101	PHASE 2 UTILITY PLAN	E-409 TYP SUSP APC DETAILS	E-410 TYP SUSP APC DETAILS
C-101	PHASE 2 UTILITY PLAN	C-102	PHASE 2 UTILITY PLAN - FIRE LINE	E-411 TYP SUSP APC DETAILS	E-412 TYP SUSP APC DETAILS
C-102	PHASE 2 UTILITY PLAN	C-201	PHASE 1 PAVEMENT STRUCTURAL SECTION & EROSION CONTROL PLAN	E-413 TYP SUSP APC DETAILS	E-414 TYP SUSP APC DETAILS
C-202	PHASE 2 PAVEMENT STRUCTURAL SECTION & EROSION CONTROL PLAN	C-202	PHASE 2 PAVEMENT STRUCTURAL SECTION & EROSION CONTROL PLAN	E-415 TYP SUSP APC DETAILS	E-416 TYP SUSP APC DETAILS
C-203	PHASE 1 LAYOUT PLAN	C-204	PHASE 2 LAYOUT PLAN	E-417 TYP SUSP APC DETAILS	E-418 TYP SUSP APC DETAILS
C-301	DETAILS	C-302	DETAILS	E-419 TYP SUSP APC DETAILS	E-420 TYP SUSP APC DETAILS
C-303	DETAILS	C-304	DETAILS	E-421 TYP SUSP APC DETAILS	E-422 TYP SUSP APC DETAILS
C-304	DETAILS	C-305	DETAILS	E-423 TYP SUSP APC DETAILS	E-424 TYP SUSP APC DETAILS
C-305	DETAILS	C-306	DETAILS	E-425 TYP SUSP APC DETAILS	E-426 TYP SUSP APC DETAILS
C-306	DETAILS	C-307	DETAILS	E-427 TYP SUSP APC DETAILS	E-428 TYP SUSP APC DETAILS
C-307	DETAILS	C-308	DETAILS	E-429 TYP SUSP APC DETAILS	E-430 TYP SUSP APC DETAILS
C-308	DETAILS	C-309	DETAILS	E-431 TYP SUSP APC DETAILS	E-432 TYP SUSP APC DETAILS
C-309	DETAILS	C-310	DETAILS	E-433 TYP SUSP APC DETAILS	E-434 TYP SUSP APC DETAILS
C-310	DETAILS	C-311	DETAILS	E-435 TYP SUSP APC DETAILS	E-436 TYP SUSP APC DETAILS
C-311	DETAILS	C-312	DETAILS	E-437 TYP SUSP APC DETAILS	E-438 TYP SUSP APC DETAILS
C-312	DETAILS	C-313			

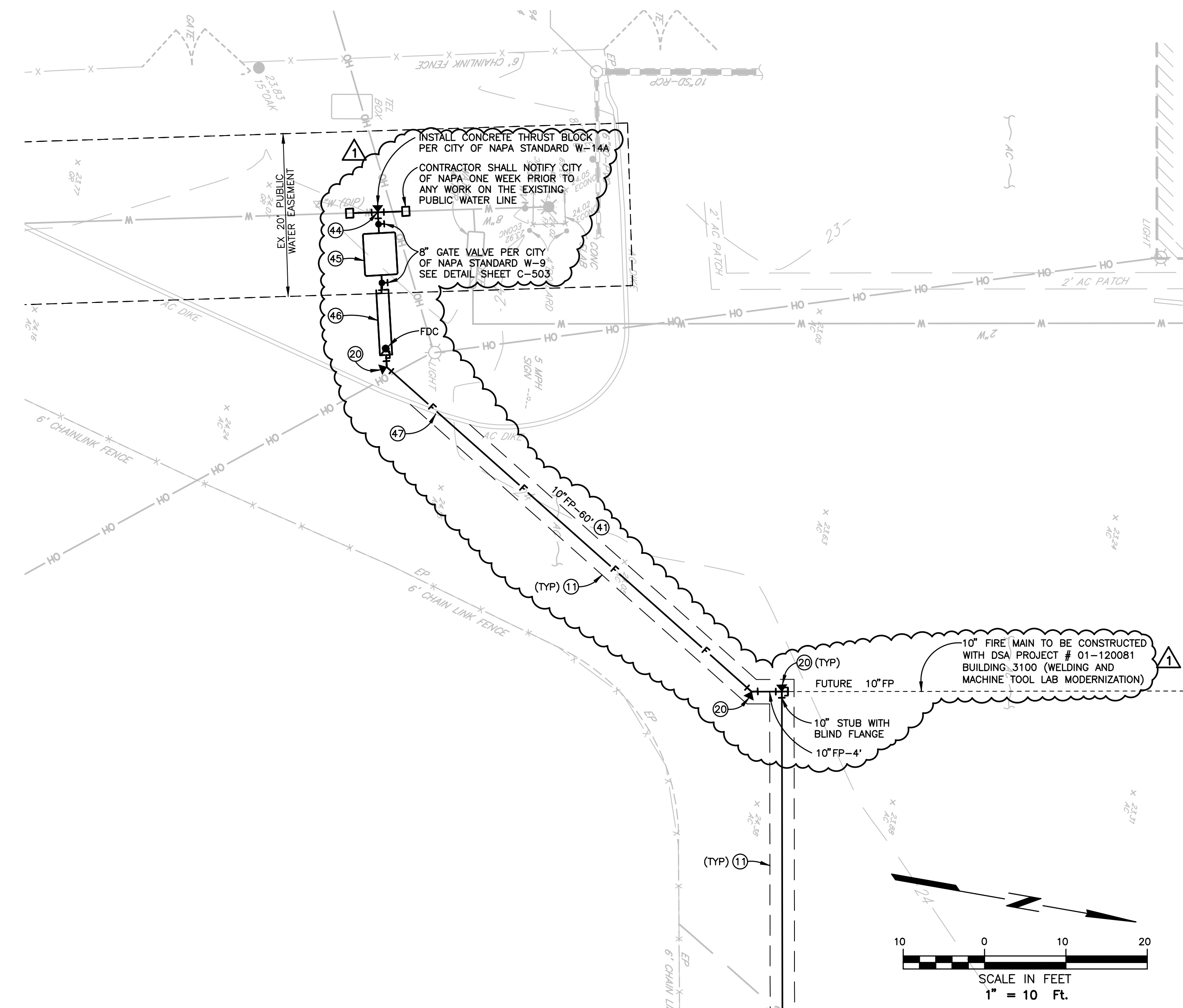

SEE ABOVE RIGHT

UTILITY NOTES

(ONLY NOTES RELEVANT TO THIS SHEET ARE SHOWN)

- 17 SAWCUT EXISTING ASPHALT PAVEMENT REMOVE AND REPLACE EXISTING ASPHALT PER STANDARD TRENCH DETAIL ON SHEET C-501.
- 18 POT HOLE AND VERIFY SIZE, LOCATION AND ELEVATIONS OF EXISTING WATER LINE BEFORE ANY WATER CONSTRUCTION. CONNECT TO EXISTING FIRE.
- 20 INSTALL CONCRETE THRUST BLOCK PER DETAIL, SEE SHEET C-501.
- 43 FIRE MAIN SHALL BE AWWA C900 CLASS 200 DR-14 PVC PIPE.
- 44 CUT IN NEW 8" TEE PER CITY OF NAPA STANDARD W-168. NOTIFY CITY OF NAPA BEFORE ANY CONSTRUCTION ON THE 8" PUBLIC WATER LINE. SEE DETAIL SHEET C-504. CONTRACTOR SHALL APPLY AND PAY FOR AN ENCROACHMENT PERMIT FROM THE CITY OF NAPA PRIOR TO ANY WORK ON THE PUBLIC WATER LINES.
- 45 INSTALL 8" WATER METER PER CITY OF NAPA STANDARD W-4C.1. SEE DETAIL SHEET C-504.
- 46 INSTALL 8" DIAMETER REDUCED PRESSURE BACKFLOW DEVICE WITH INTEGRAL 4" 90 DEGREE FDC PUMPER CONNECTION WITH DUAL 2 1/2" OUTLETS (PER CITY OF NAPA STANDARD W-6C). SEE DETAIL SHEET C-504.
- 47 REPAIR EXISTING ASPHALT DIKE AS NECESSARY TO INSTALL NEW FIRE LINE.

GENERAL NOTES

- 1. CONTACT THE CITY OF NAPA WATER DIVISION FOR ANY WORK DETERMINED IN THE FIELD TO CONFLICT WITH THE CITY'S WATER FACILITIES.
- 2. CONTACT THE CITY OF NAPA WATER DIVISION TO COORDINATE GPS DATA COLLECTION PRIOR TO INSTALLATION OF ANY PUBLIC OR PRIVATE WATERLINES.

SEE LEFT MIDDLE

SEE SHEET C-102

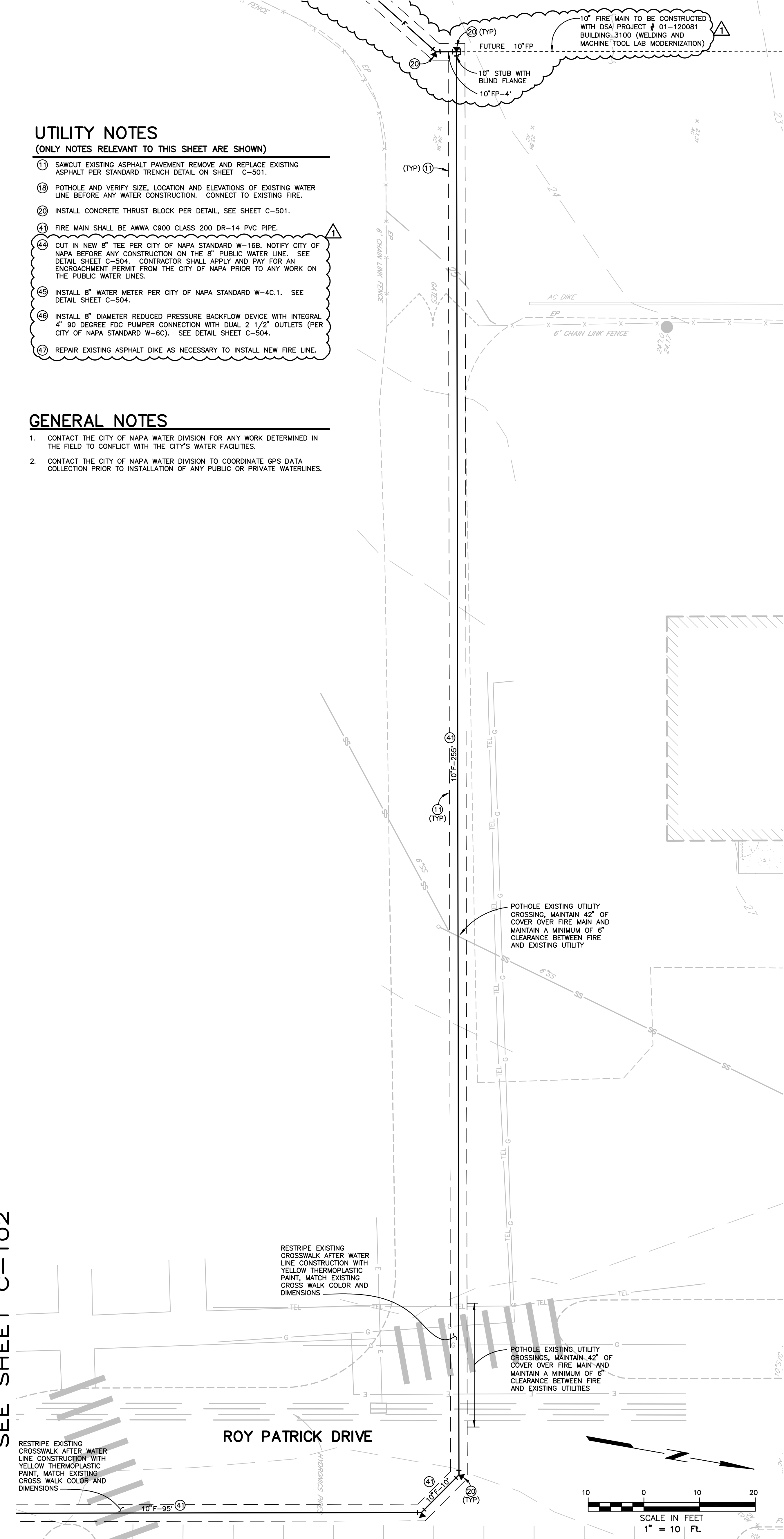

GRADING NOTES

(ONLY NOTES RELEVANT TO THIS SHEET ARE SHOWN)

- 1 SAWCUT AND MATCH EXISTING IMPROVEMENTS.
- 39 INSTALL EMBEDDED DETECTABLE WARNING SURFACE PER DETAIL SHEET C-502.
- 40 SAWCUT AND REMOVE EXISTING DETECTABLE WARNING SURFACE AND CONCRETE. INSTALL NEW CONCRETE PER PEDESTRIAN PCC WALK SECTION DETAIL SHEET C-501. MATCH EXISTING SURROUNDING CONCRETE COLOR AND FINISH.
- 46 SAWCUT REMOVE EXISTING CONCRETE. INSTALL NEW CONCRETE PER PEDESTRIAN PCC WALK SECTION DETAIL SHEET C-501. INSTALL 3" WIDE EMBEDDED DETECTABLE WARNING SURFACE PER DETAIL SHEET C-502.

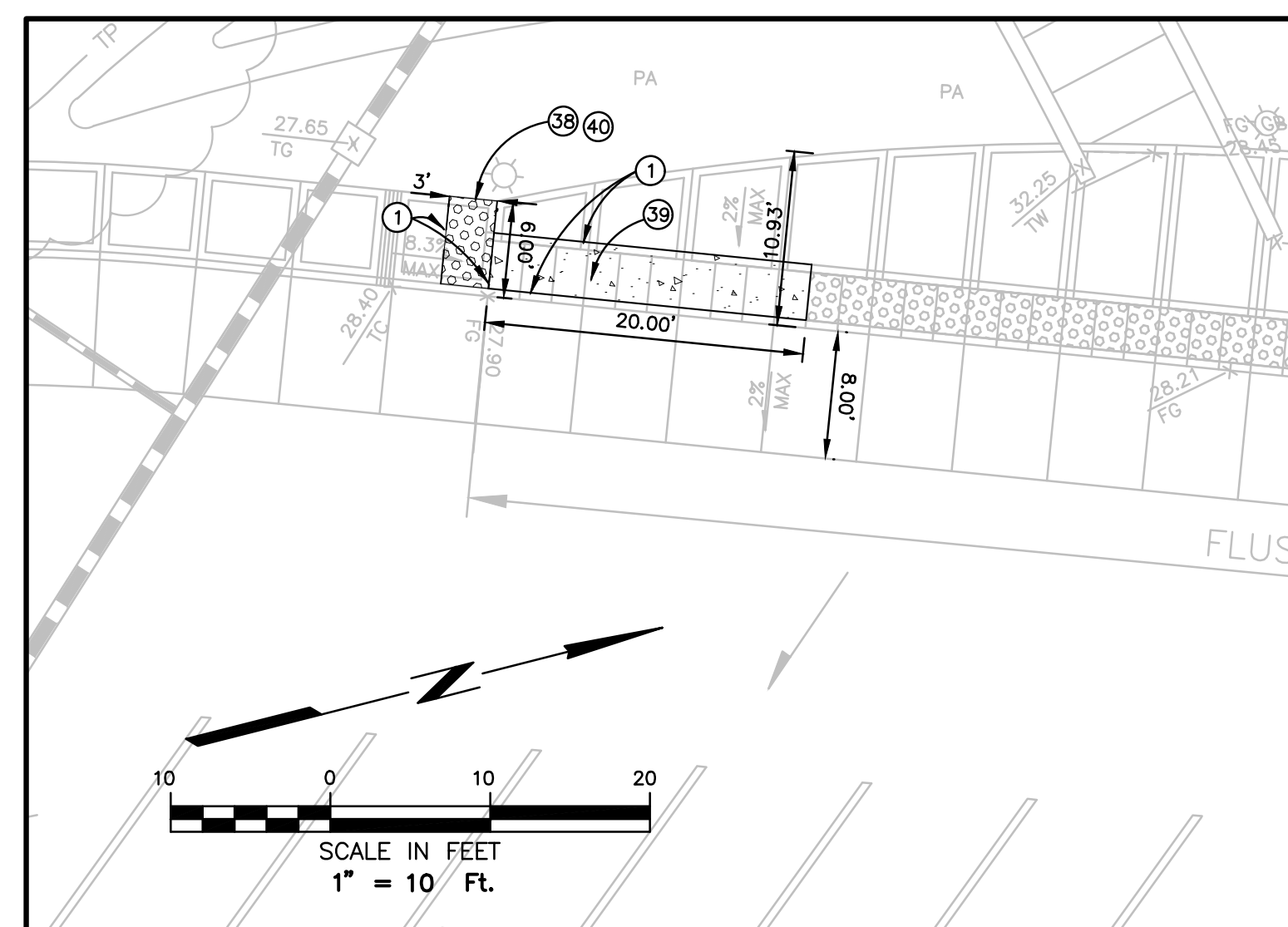

GRADING PLAN

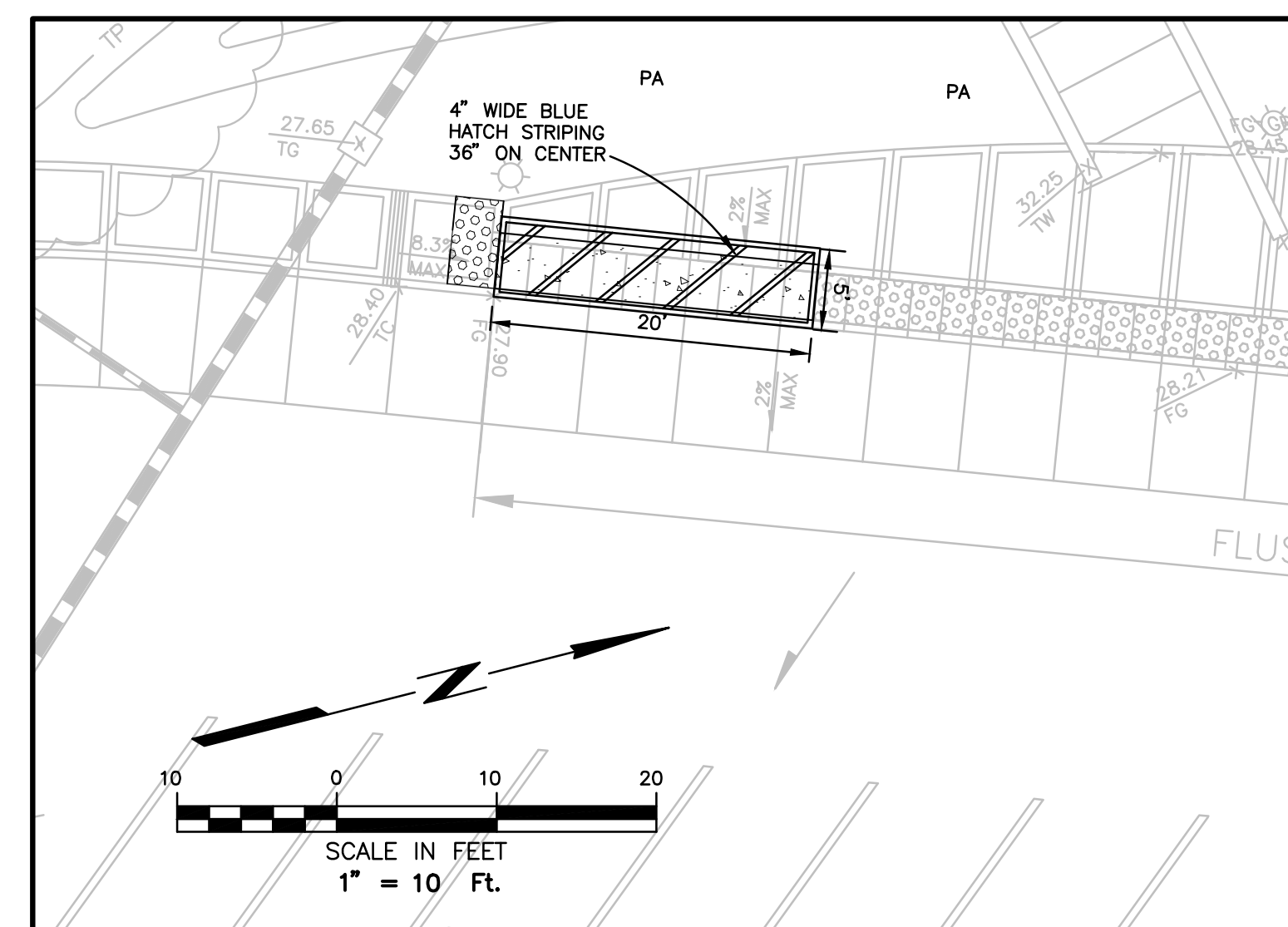

STRIPING PLAN

ACCESSIBLE DROP OFF AREA EAST
(REFERENCE ARCHITECTURAL PLAN SHEET G-002)

TLCDARCHITECTURE

520 Third St. #250
Santa Rosa, CA 95401
o: 707.525.5600
f: 707.525.5616
tcd.com

Brelje & Race

CONSULTING ENGINEERS
475 Aviation Boulevard, Suite 120
Santa Rosa, CA 95403
v: 707-576-1322
f: 707-576-0469
www.brce.com

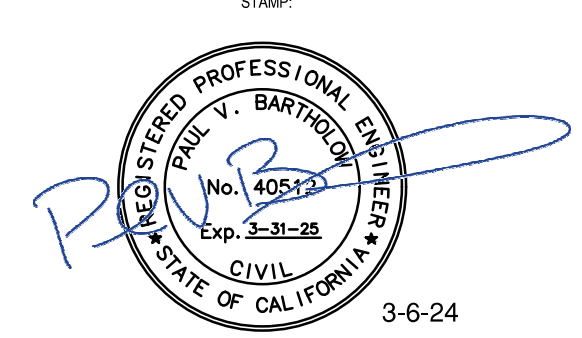

Number	Date	Description
1	3/6/24	ADDENDUM 1

NAPA VALLEY COLLEGE WINE EDUCATION CENTER
2277 NAPA VALLEJO HWY
NAPA, CA 94558

NAPA VALLEY COLLEGE

DSA APPLICATION NUMBER
014-20860
TLD PROJECT NUMBER
21062/2701.17
DATE
8/30/2023
DRAWN BY
PJT
CHECKED BY
RG

**PHASE 1 UTILITY PLAN
FIRE LINE &
EAST DROP OFF AREA**

C-103

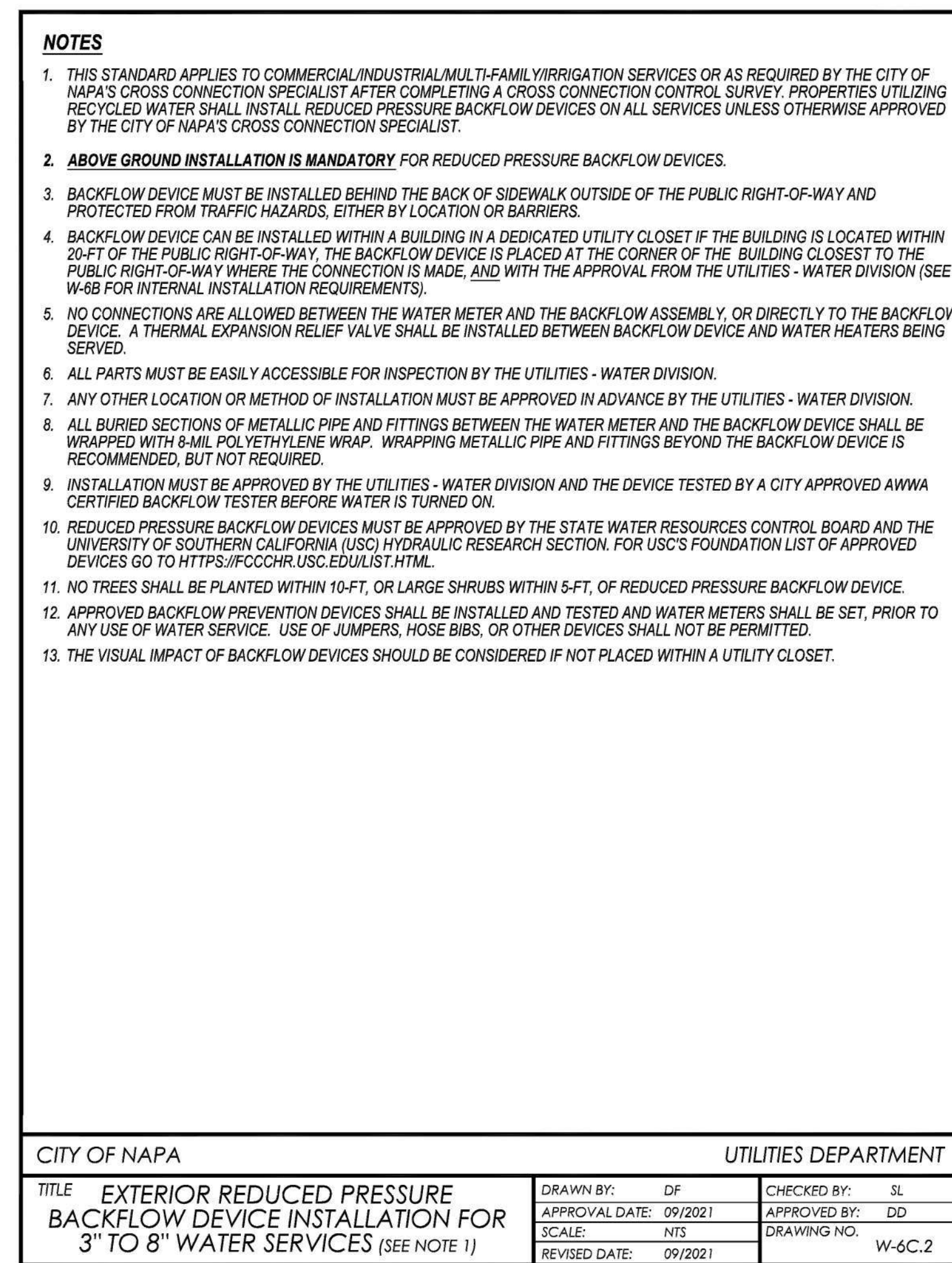
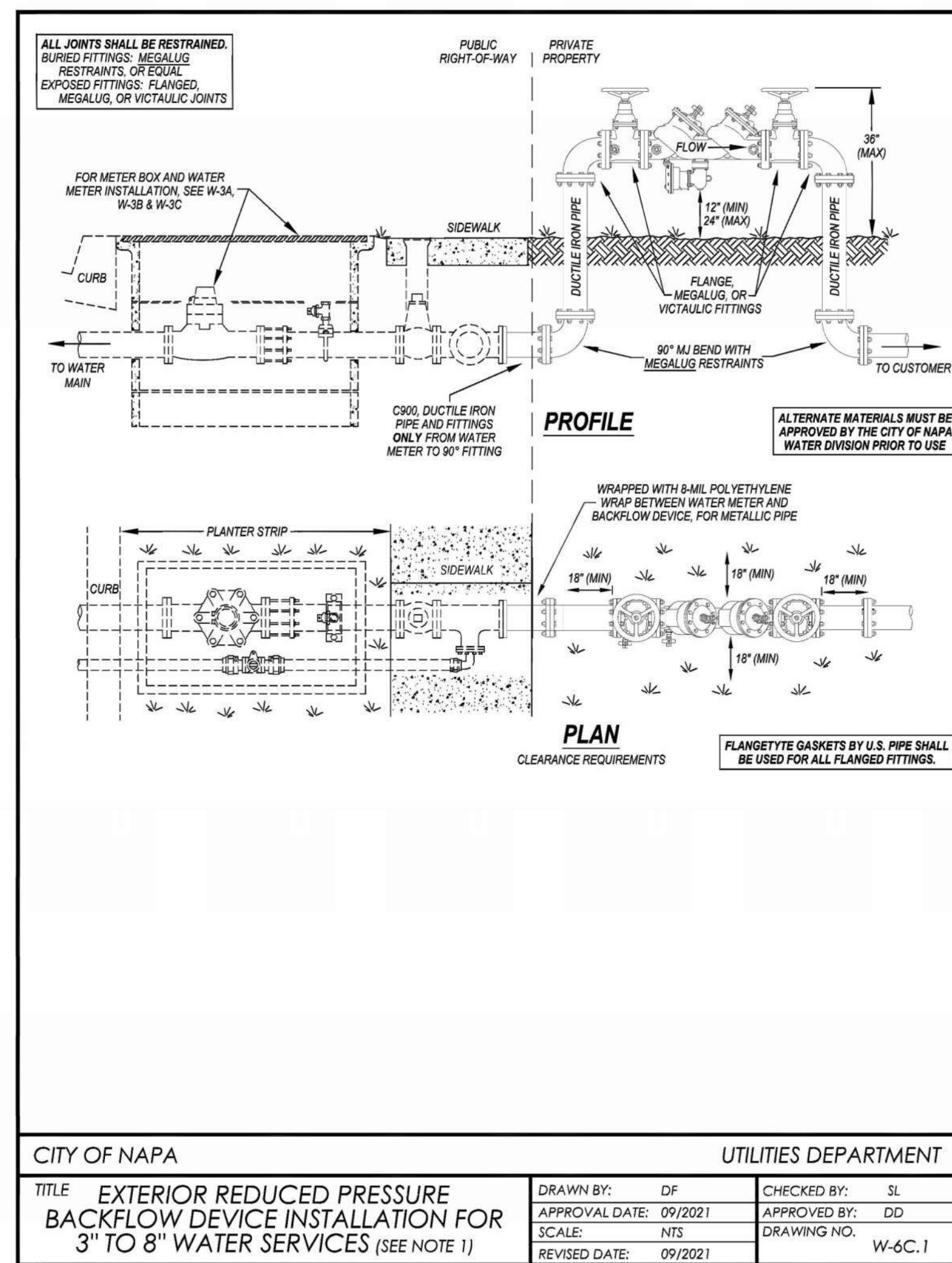
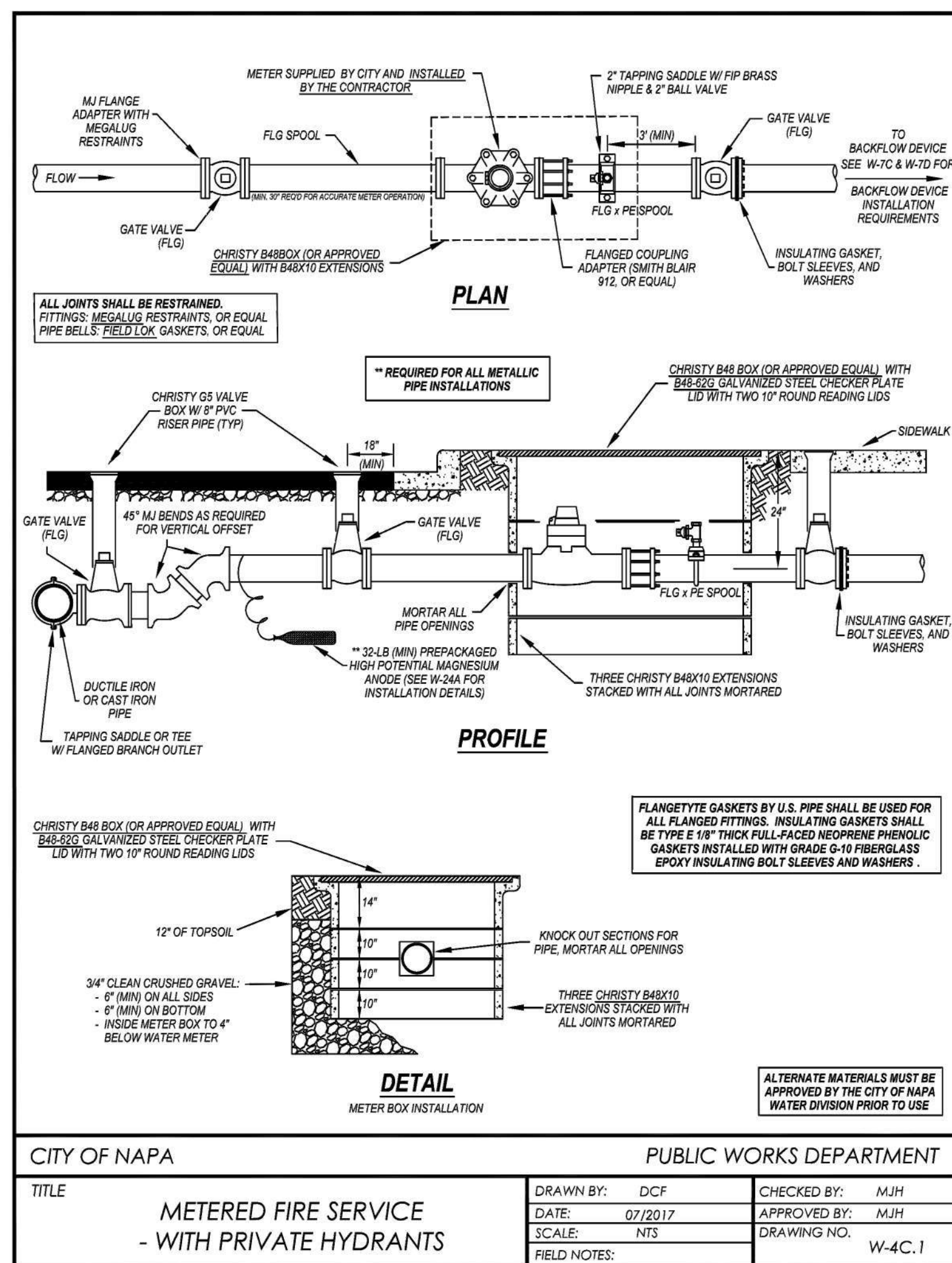
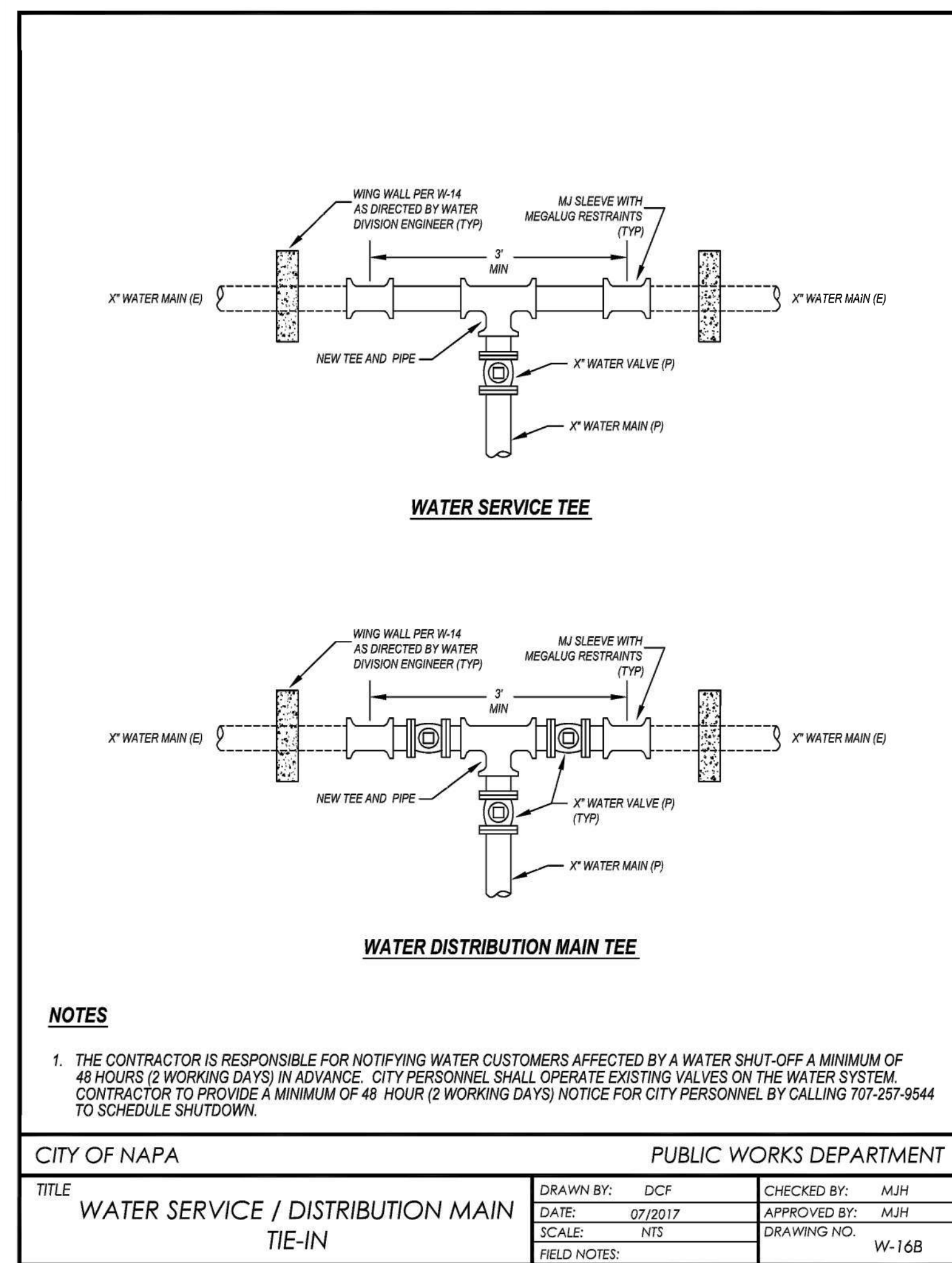
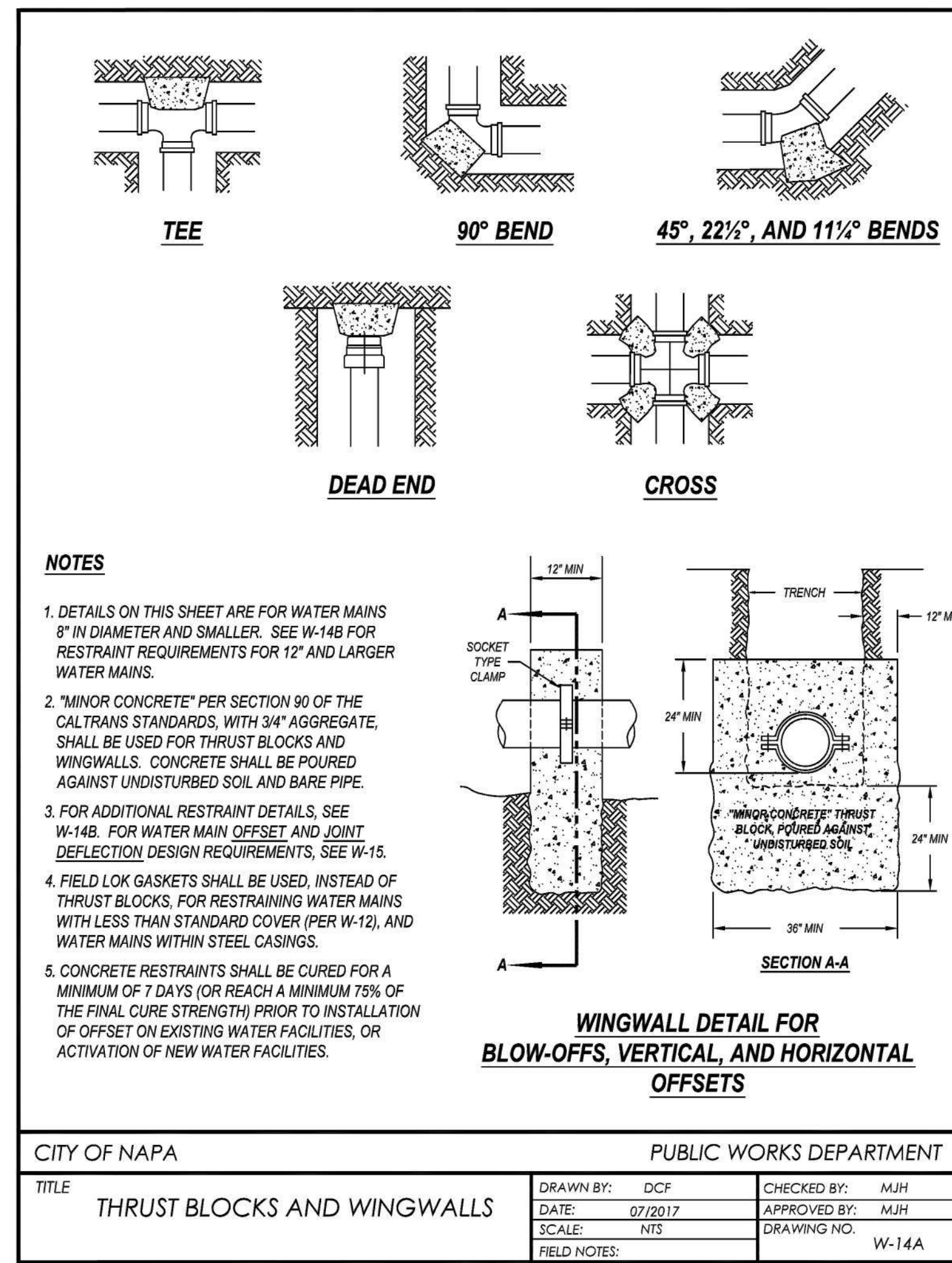
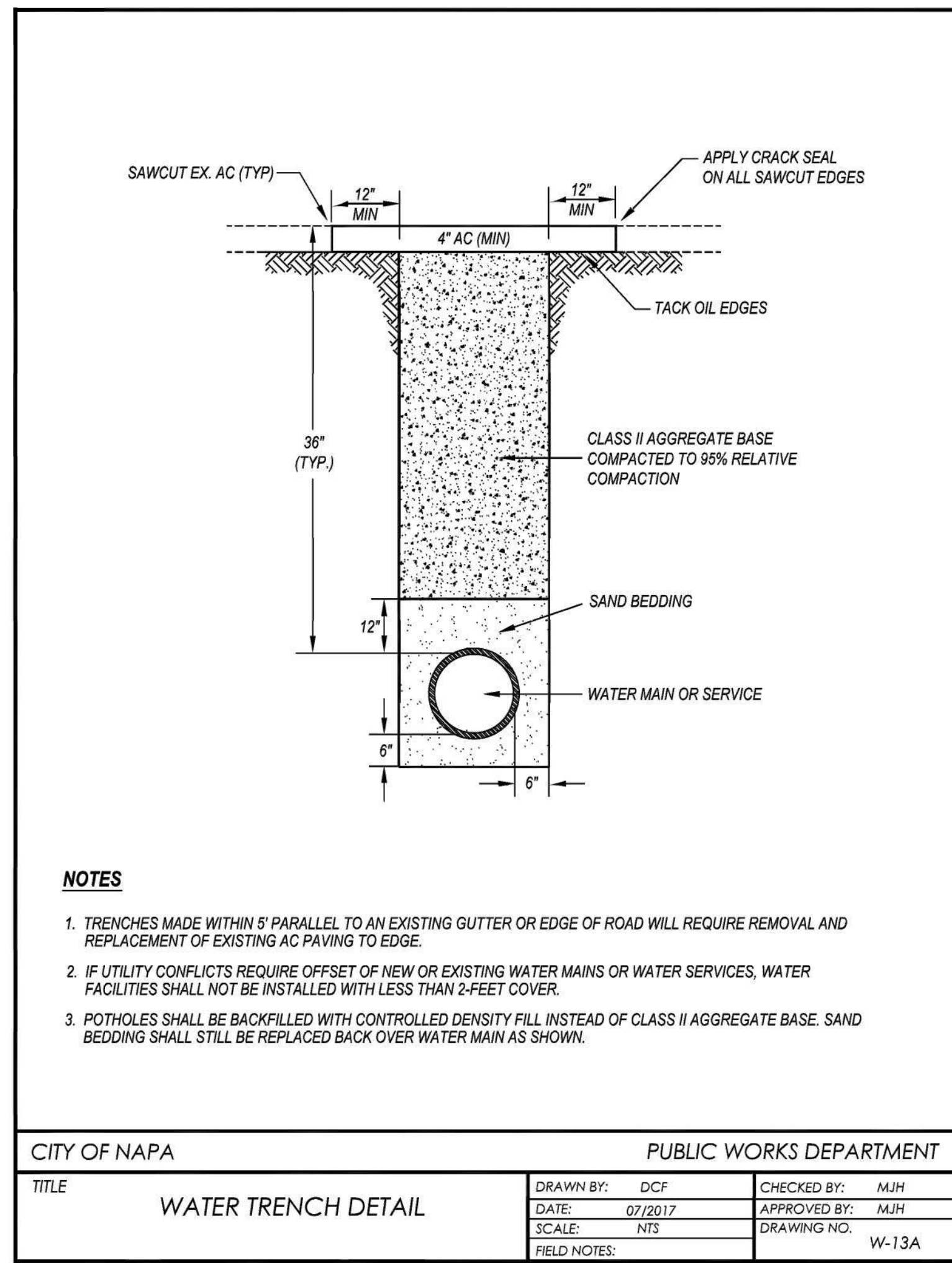

TLCD ARCHITECTURE
 520 Third St. #250
 Santa Rosa, CA 95401
 o: 707.525.5600
 f: 707.525.5616
 tlcd.com

Brelje & Race
 CONSULTING ENGINEERS
 475 Aviation Boulevard, Suite 120
 Santa Rosa, CA 95403
 v: 707-576-1322
 f: 707-576-0469
 www.brce.com

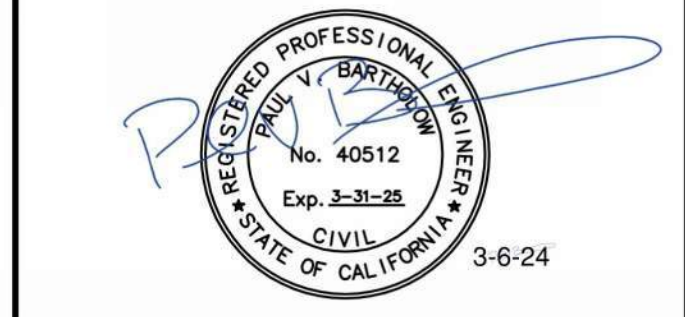

Number	Date	Description
1	3/6/24	ADDENDUM 1

NAPA VALLEY COLLEGE WINE EDUCATION CENTER
 2277 NAPA VALLEJO HWY
 NAPA, CA 94558

NAPA VALLEY COLLEGE

DDA APPLICATION NUMBER: 01-120890
 TLCD PROJECT NUMBER: 210622701.17
 DATE: 8/30/2023
 DRAWN BY: PTT
 CHECKED BY: RG

DETAILS

C-504

03-06-24 glesson \2701.dwg\2701 17x2701.17 DETAIL.dwg
 TAB: C-504 DETAILS



GENERAL DEMOLITION NOTES:
 A. SEE G-002 FOR ADDITIONAL DEMOLITION WORK REQUIRED AT PASSENGER DROP-OFF AREA.

- DEMOLITION DRAWING NOTES**
- D.01 REMOVE (E) PAVING AS REQUIRED FOR NEW WORK, SCD
 - D.02 REMOVE (E) CONCRETE CURB, SCD
 - D.03 REMOVE (E) CONCRETE FLATWORK, SCD TYP
 - D.04 REMOVE (E) LIGHT STANDARD AND CONCRETE BASE, SED FOR ASSOCIATED WORK, TYP
 - D.05 REMOVE (E) TREES, PLANTINGS AND ASSOCIATED IRRIGATION, SLD
 - D.06 REMOVE (E) MODULAR BUILDING, FOUNDATION SYSTEM AND ASSOCIATED UTILITIES
 - D.07 REMOVE (E) PAVEMENT MARKINGS
 - D.08 REMOVE (E) RAISED PLANTER(S), TYP
 - D.09 AREA OF (N) TRANSFORMER INSTALLATION, SCD & SED FOR ASSOCIATED WORK
 - D.10 REMOVE (E) GATE AND ASSOCIATED HARDWARE
 - D.11 (E) BUILDING, FOUNDATION AND UTILITIES TO BE REMOVED AS PART OF PHASE 1 WORK (E) UTILITIES TO BE CAPPED, SCD
 - D.12 (E) CONCRETE FLATWORK, LANDSCAPING, IRRIGATION, UTILITIES, ETC ASSOCIATED WITHIN THE PHASE 2 AREA TO BE REMOVED AS REQUIRED FOR PHASE 2 PAD PREPARATION
 - D.13 (E) OAK TREE, PROTECT DURING CONSTRUCTION, SLD
 - D.15 REMOVE PAVING AT REMOVED ACCESSIBLE PARKING, SCD
 - D.16 SALVAGE AND CRATE (E) ART SCULPTURE, DELIVER TO COLLEGE MAINTENANCE FACILITY ON SITE

AGENCY APPROVAL STAMP

TLCDARCHITECTURE

520 Third St. #250
 Santa Rosa, CA 95401
 o: 707.525.5600
 f: 707.525.5616
 tcd.com

CONSULTANT

STAMP

LICENSED ARCHITECT
 CAROL SERVICE
 C-32947
 REN121325
 STATE OF CALIFORNIA

REVISIONS

Number	Date	Description
1	3/6/24	ADDENDUM 1

NAPA VALLEY COLLEGE WINE EDUCATION CENTER
 2277 NAPA VALLEJO HWY
 NAPA, CA 94558



2 ART SCULPTURE
 12" = 1'-0"

1 PARTIAL SITE PLAN - DEMOLITION
 1" = 10'-0"

PARTIAL SITE PLAN - DEMOLITION WORK

A-101

3/5/2024 5:54:28 PM

© THESE DRAWINGS ARE INSTRUMENTS OF SERVICE AND ARE THE SOLE PROPERTY OF TLCD ARCHITECTURE. ANY USE WITHOUT WRITTEN CONSENT IS PROHIBITED.

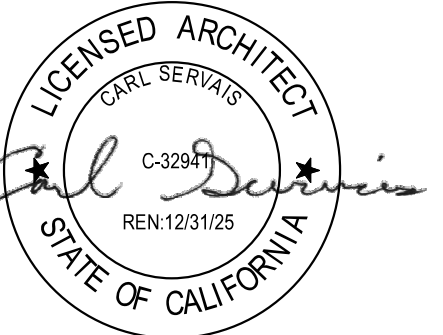

Number	Date	Description
1	3/6/24	ADDENDUM 1

REFERENCE KEYNOTE

- 05 50 00.A METAL FABRICATIONS - LADDER
- 08 35 40 SLIDING ALUMINUM AND GLASS WALLS
- 08 41 00 ENTRANCES AND STOREFRONTS
- 09 65 10 RESILIENT BASE AND ACCESSORIES
- 10 14 00.L SIGNAGE - EXIT, SEE 20/A-511
- 10 14 00.M SIGNAGE - ROOM SIGNAGE, SEE 20/A-511
- 10 14 00.R SIGNAGE - MAXIMUM OCCUPANCY 181
- 10 44 00.A FIRE PROTECTION CABINET - SEMI-RECESSED
- 12 36 61 SOLID SURFACING COUNTERTOPS - 1" EPOXY RESIN
- 22 00 00 PLUMBING FIXTURE, SPD
- 26 51 01.A LIGHTING FIXTURE (TYP), SED
- 26 51 01.B EMERGENCY LIGHTING - EXIT SIGN (TYP), SED
- 28 31 00 FIRE DETECTION AND ALARM, SPD

DRAWING NOTES

- .024 EPOXY RESIN COUNTERTOP WITH 3/4" EPOXY RESIN SIDE / BACKSPLASH
- .031 1/4" BLACKENED STEEL PLATE PANELS WITH BLACK PAN HEAD FASTENERS
- .032 RICHLITE STRATUM 1" THICK COUNTERTOP - BAMBOO BLACK DIAMOND LEATHERED FINISH
- .033 CUSTOM FABRICATED BLACKENED STEEL FOOT RAIL WITH POST EPOXY SET INTO CONCRETE FLOOR
- .034 4' X 8' DRY ERASE WHITEBOARD WITH TRAY
- .038 CABINET DOOR PANEL WITH VERTICAL SLIDING DOOR HARDWARE. CUSTOM COLOR DOOR PANEL TO MATCH WALL. CENTER OPENING ON CABINET BELOW
- .041 UNDERCOUNTER WINE COOLER TO FIT UNDER ADA COUNTER HEIGHT, SED FOR ASSOCIATED WORK
- .042 UNDER COUNTER COMMERCIAL GRADE GLASSWARE WASHER, CFI, MIELE PROFESSIONAL PG 061 U, 28V, STAINLESS STEEL FINISH WITH GLASSWARE BASKETS. CONFIRM ACCESSORIES WITH COLLEGE REPRESENTATIVE. SUBMIT PRODUCT INFORMATION FOR APPROVAL. PRIOR TO PURCHASE. SED & SPD FOR ASSOCIATED WORK
- .055 6/8 X 8 SAS VERTICAL GRAIN DOUGLAS FIR BOARDS OVER 8/8 PLYWOOD SHEATHING - ALIGN JOINTS WITH CEILING BOARDS. FINISH WITH CLEAR SATIN POLYURETHANE COATING (SPRAY APPLIED)
- .074 ACOUSTICAL WALL PANEL (WP-1) AT 41° TO SLOPED CEILING THIS WALL
- .078 EXPOSED FIRE SPRINKLER LINES, HANGERS, ETC TO BE PAINTED WITH HIGH PERFORMANCE COATING TO MATCH SW 7099 IRON ORE
- .080 ELECTRICAL PANEL, SED
- .081 5' X 12" WOOD BASE - PAINT TO MATCH WALL, SATIN FINISH
- .083 CLOCK TO MATCH CAMPUS STANDARD, SED. CENTER ON OPENING BELOW
- .085 CABINET END PANEL WITHOUT TOE KICK - TYP AT ALL CONDITIONS WHERE CABINET IS NOT AGAINST A WALL
- .088 MECHANICAL REGISTER - SMD, TYP
- .095 LIGHT FIXTURES CENTERED ON WOOD PANEL, TYP
- .096 OUTLETS, SWITCHES FACEPLATES, ETC AT WOOD WALL TO BE BLACK FINISH. ALL OTHER LOCATIONS WHITE
- .110 COUNTERTOP SUPPORT BRACKET, TYP OF (5), CENTER AT PANEL JOINT EXCEPT AT ENDS CENTER ON SCREW LINE BELOW
- .117 ELECTRICAL AND/OR DATA OUTLETS, SED
- .127 WRAP EXPOSED DIMENSIONAL WOOD LEDGER IN GYP BD AND PAINT TO MATCH SURROUND
- .130 CENTER CABINET ON WOOD PANELING JOINT
- .132 LOW ENERGY DOOR ACTUATOR, SED FOR ASSOCIATED WORK & DTL 19A-622

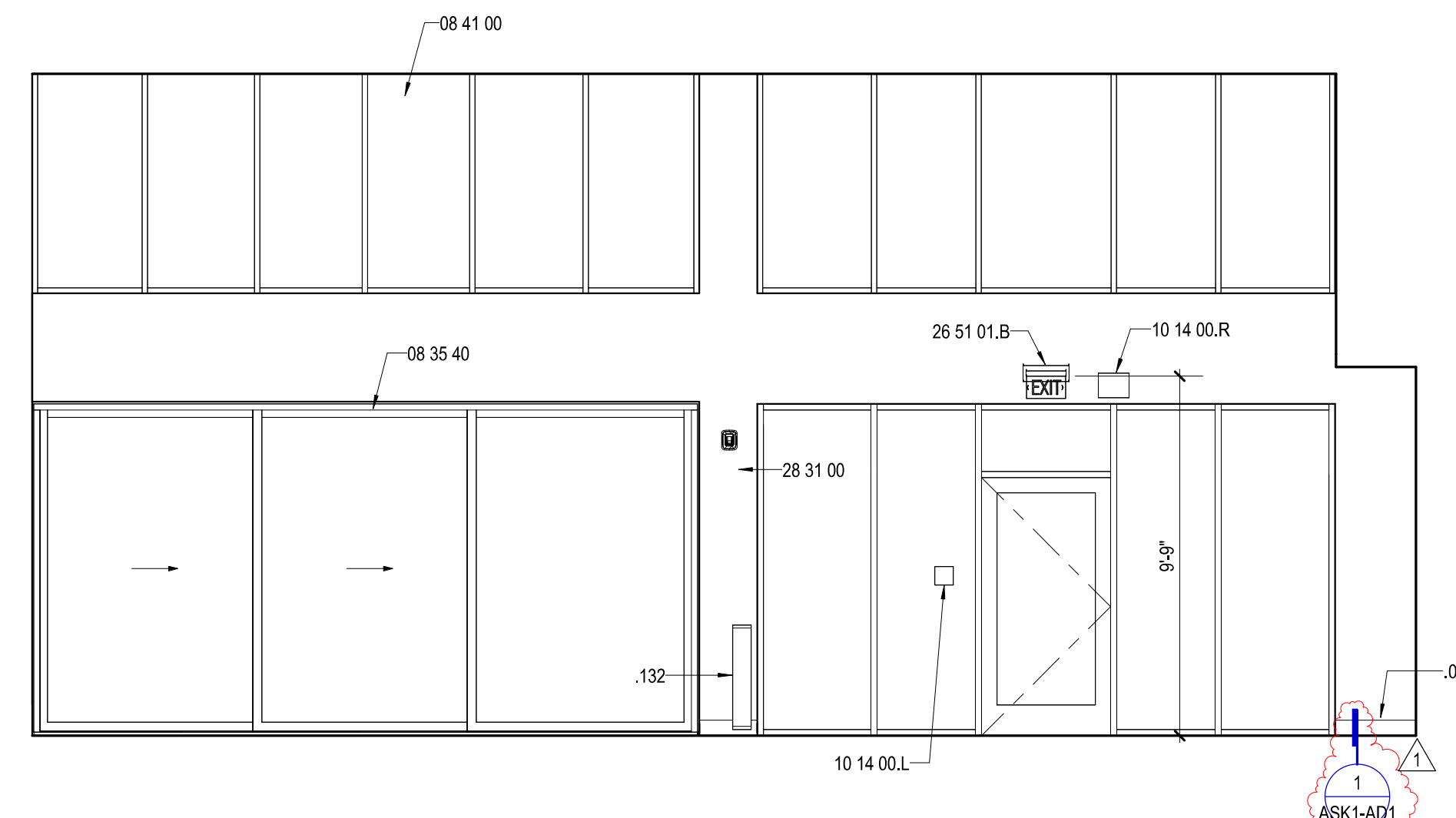

6A 116 HOSPITALITY - NORTH
 1/4" = 1'-0"

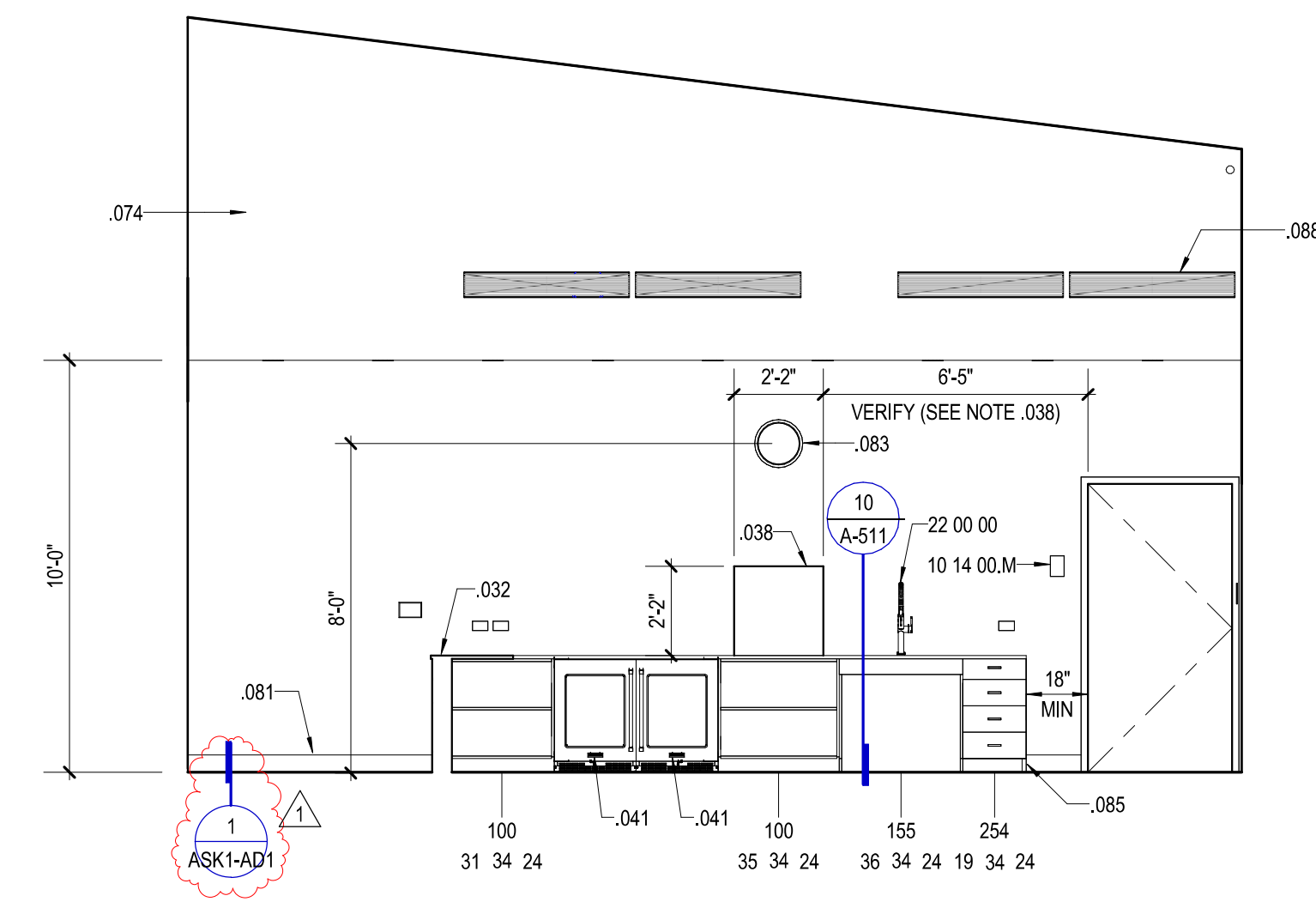

6B 116 HOSPITALITY - EAST
 1/4" = 1'-0"

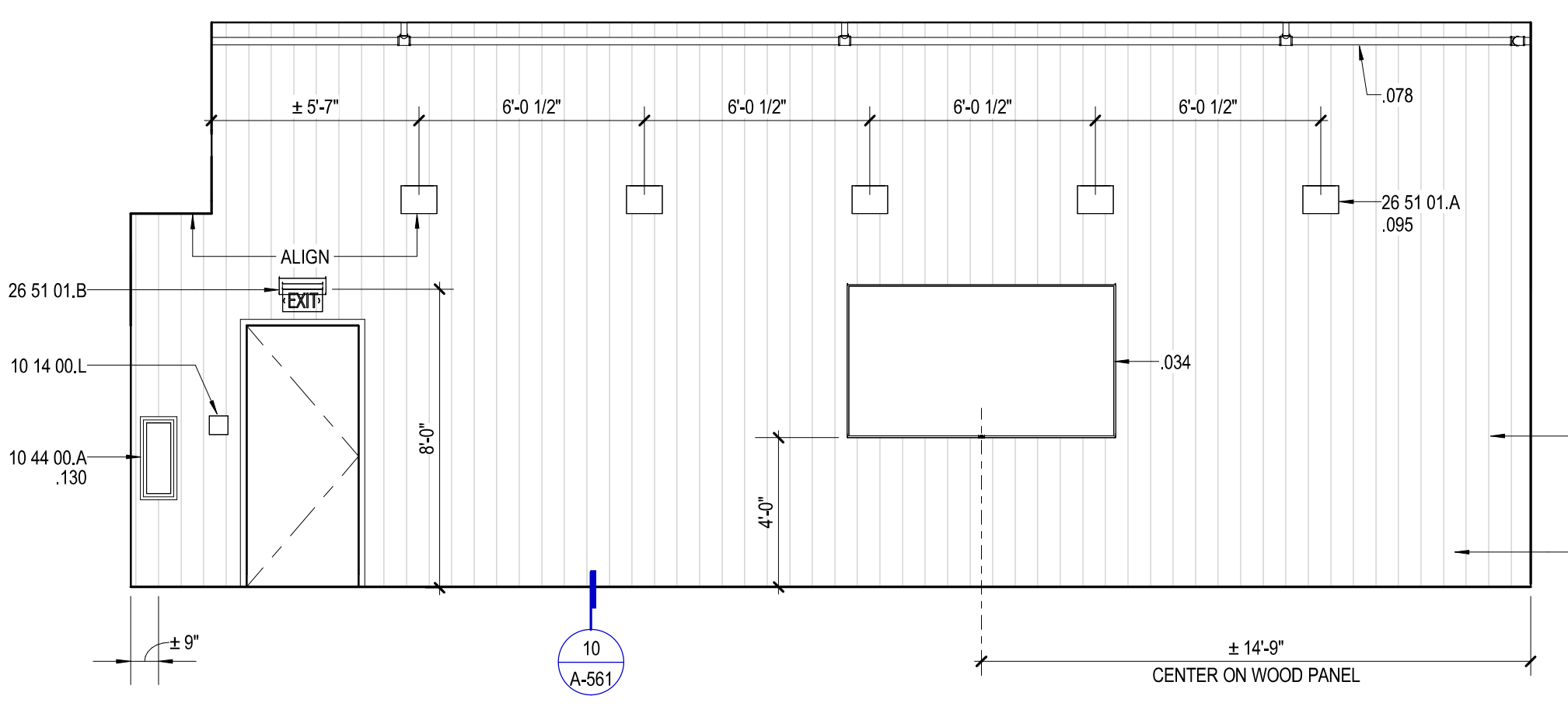

6C 116 HOSPITALITY - SOUTH
 1/4" = 1'-0"

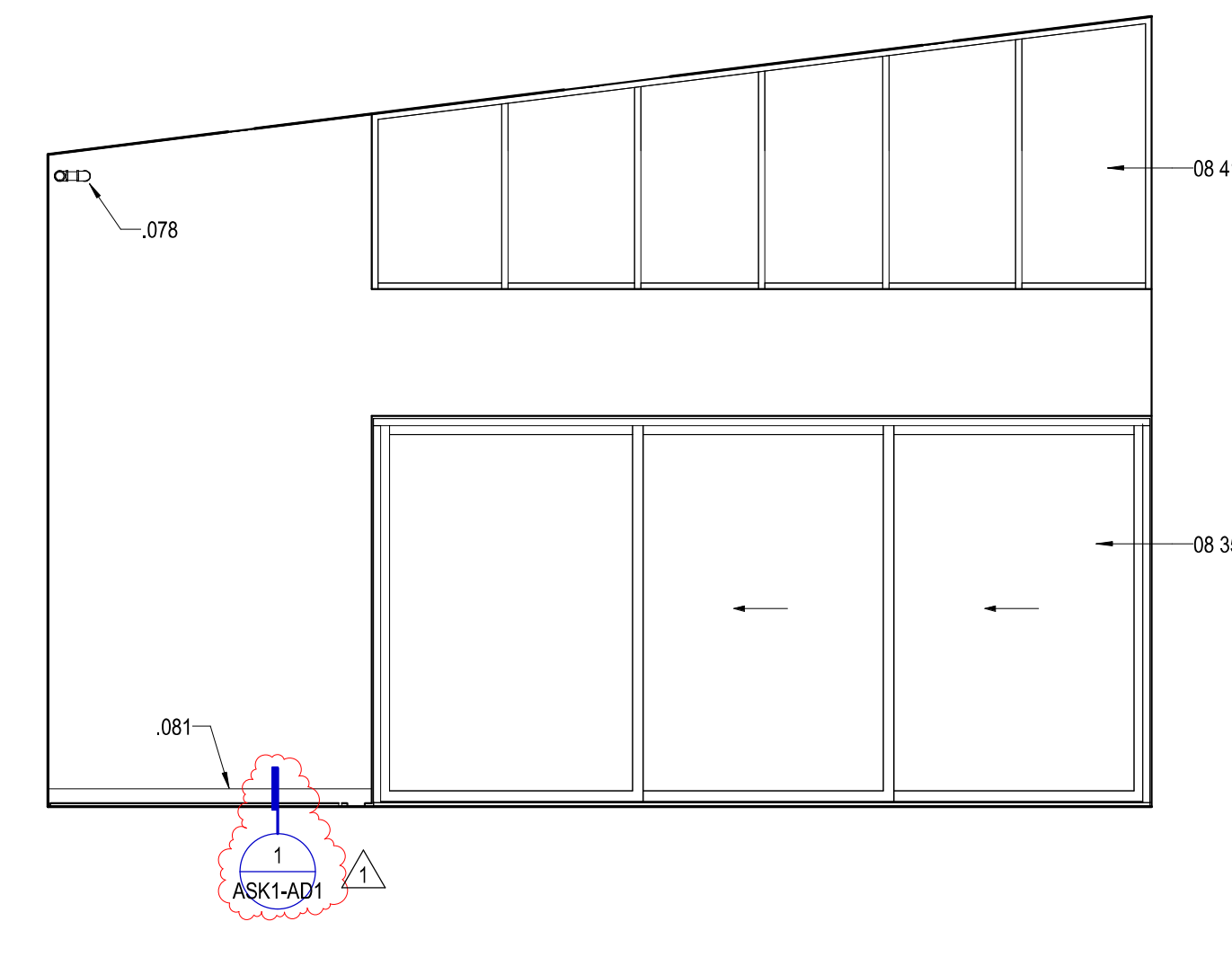

6D 116 HOSPITALITY - WEST
 1/4" = 1'-0"

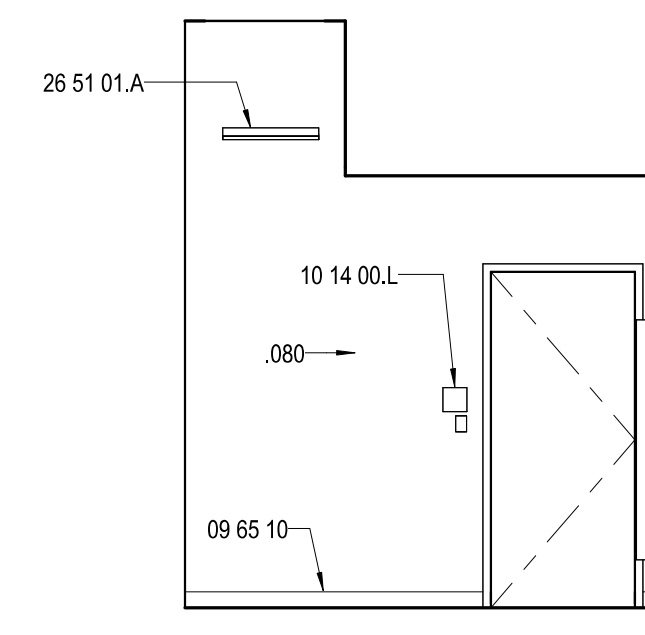

7A 117 PREP - NORTH
 1/4" = 1'-0"

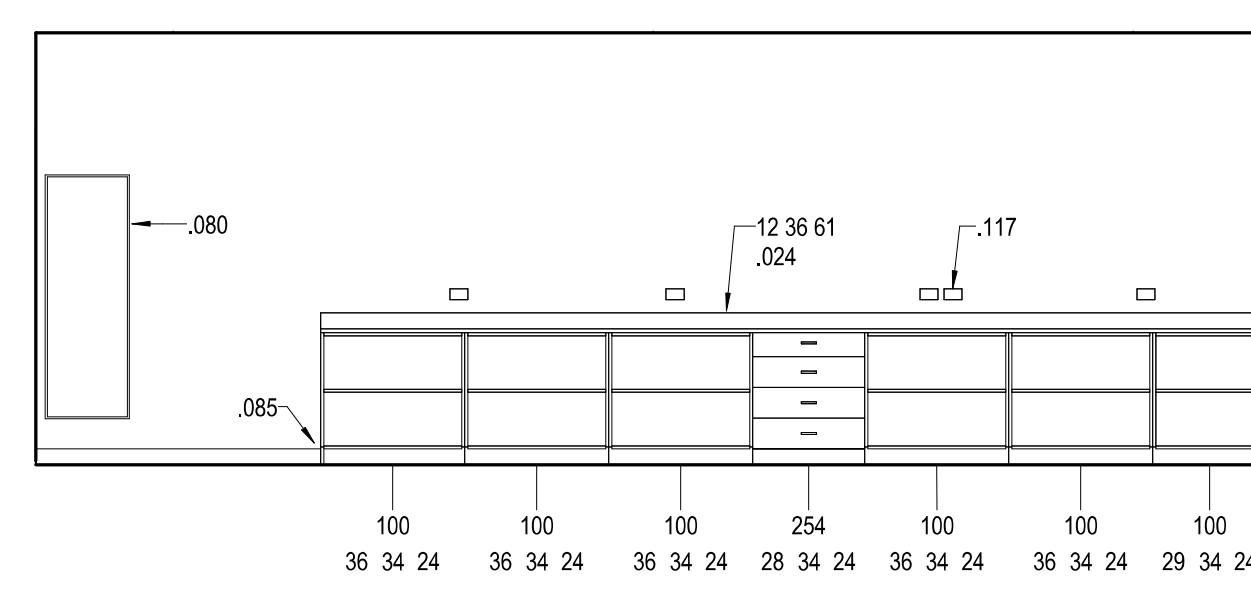

7B 117 PREP - EAST
 1/4" = 1'-0"

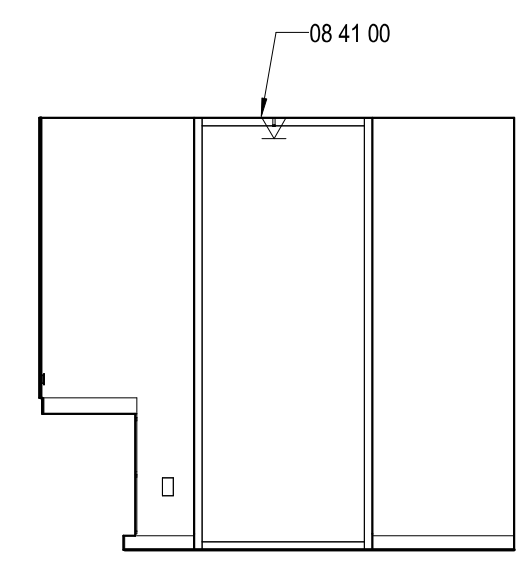

7C 117 PREP - SOUTH
 1/4" = 1'-0"

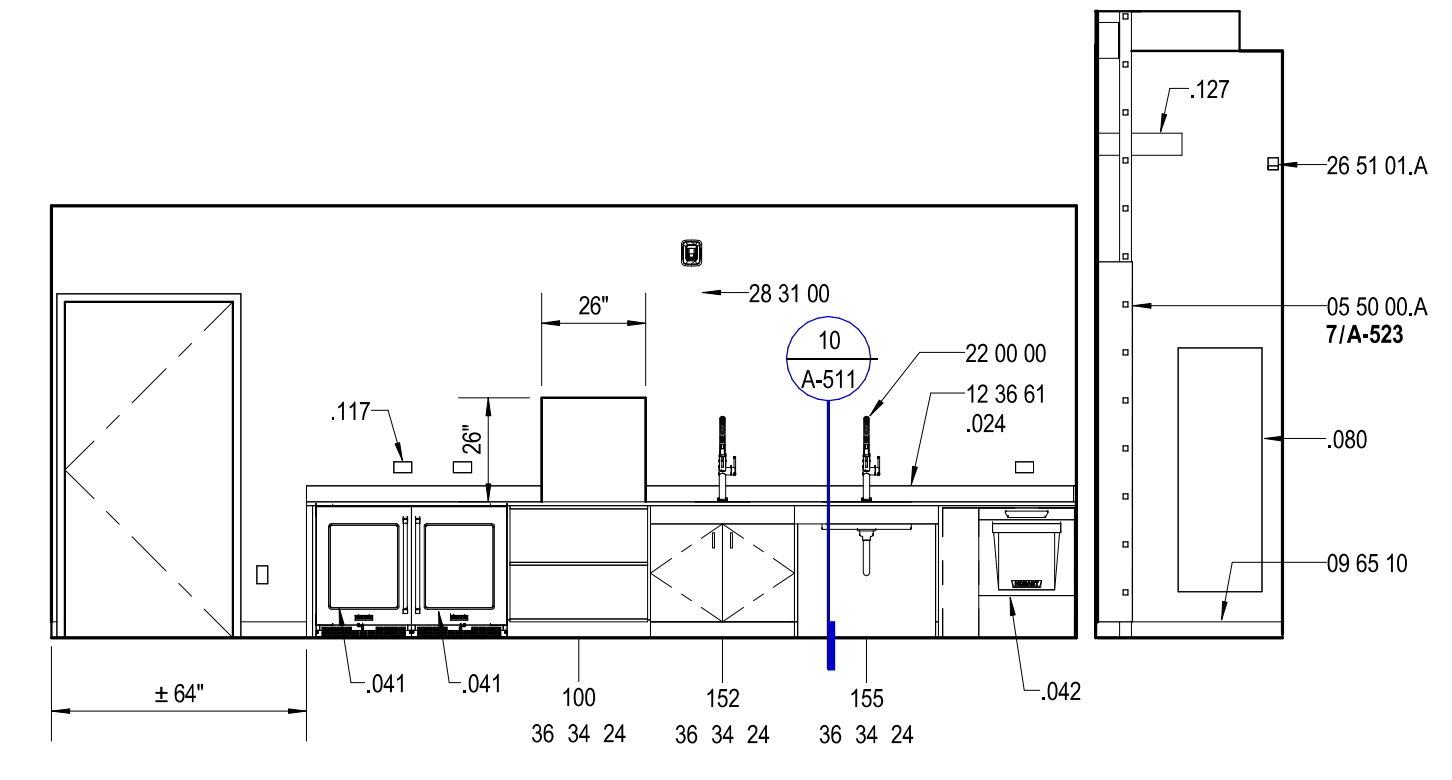

7D 117 PREP - WEST
 1/4" = 1'-0"

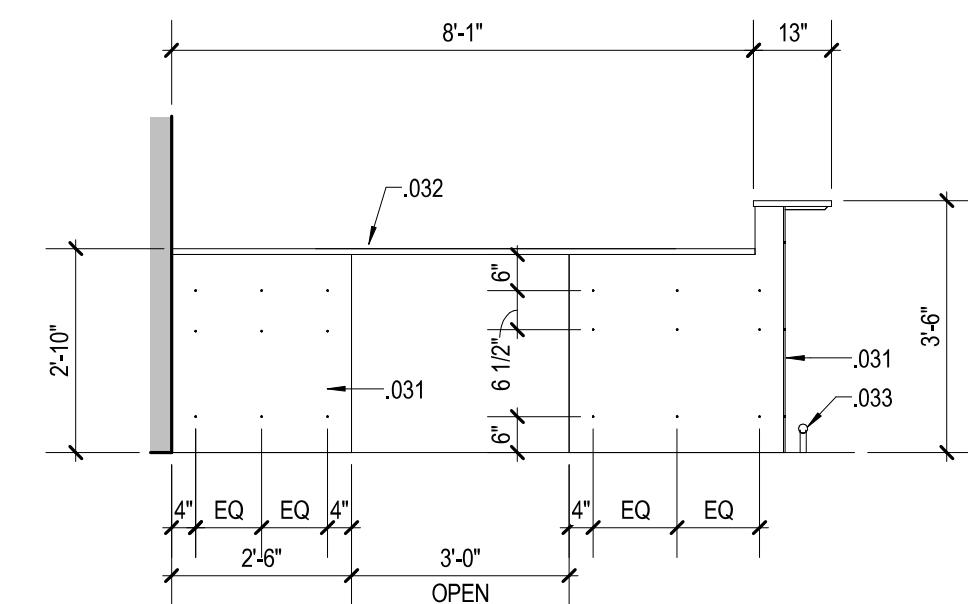

8A 116 HOSPITALITY BAR - NORTH
 3/8" = 1'-0"

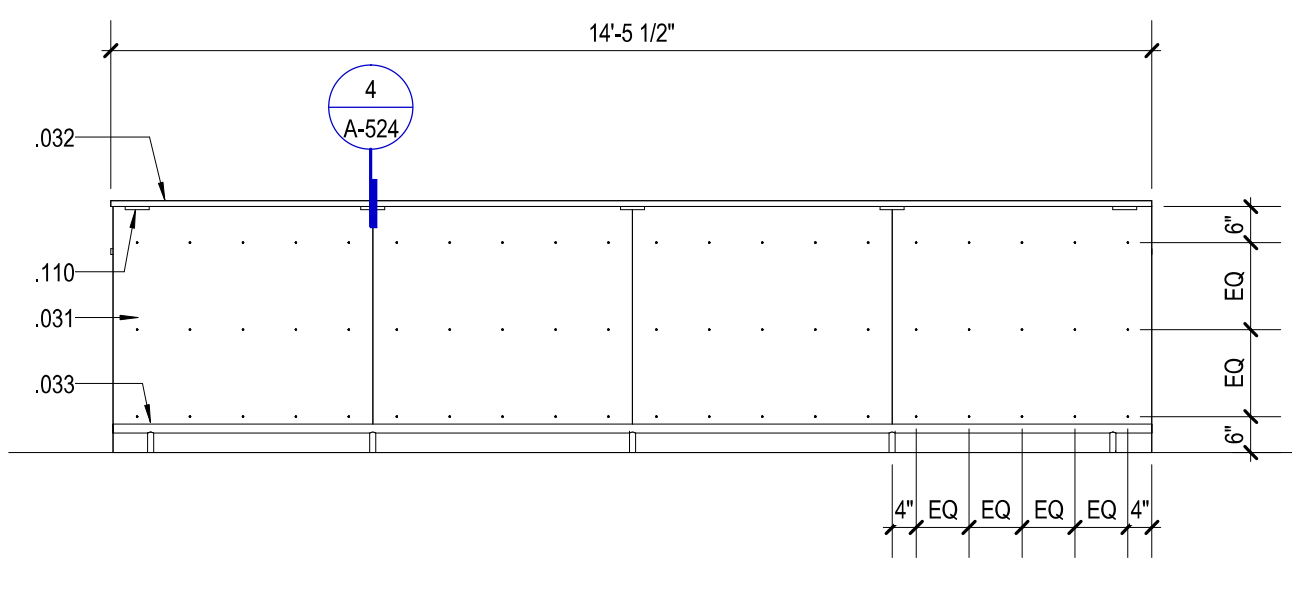

8B 116 HOSPITALITY BAR - EAST
 3/8" = 1'-0"

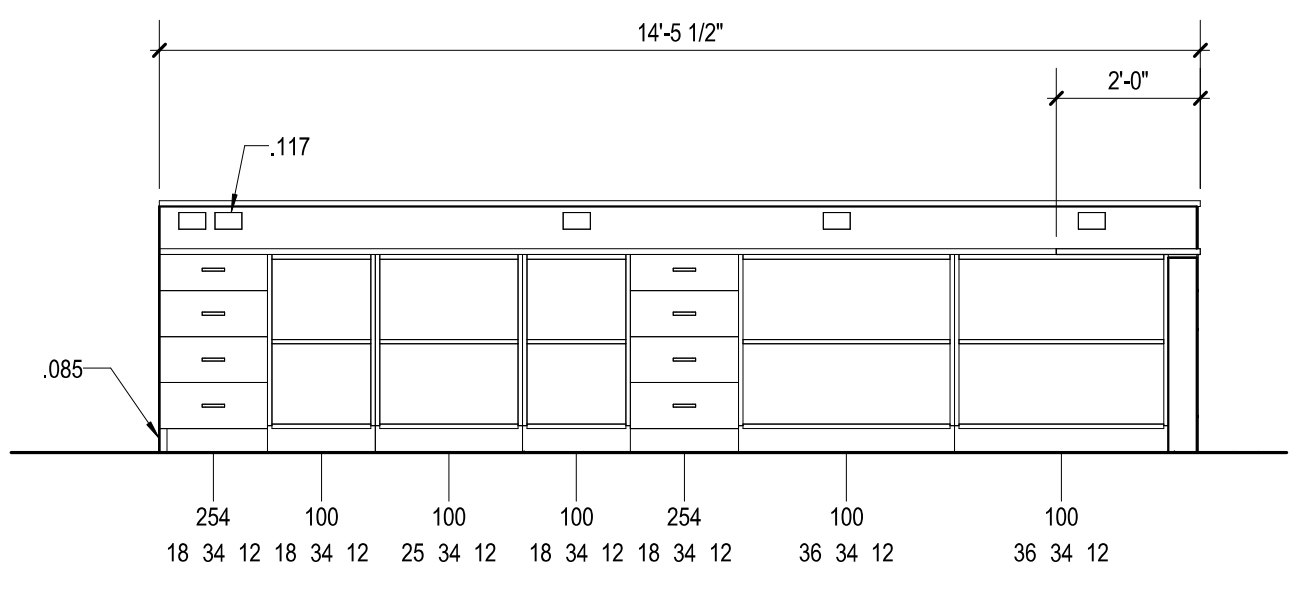

8C 116 HOSPITALITY BACK BAR - WEST
 3/8" = 1'-0"

NAPA VALLEY COLLEGE WINE EDUCATION CENTER
 2277 NAPA VALLEJO HWY
 NAPA, CA 94558



CSA APPLICATION NUMBER:
 01-120890
 TLCD PROJECT NUMBER:
 21062.00
 DATE:
 04/12/2023

INTERIOR ELEVATIONS - PHASE 2

PROJECT NAME

**NAPA VALLEY
 COLLEGE WINE
 EDUCATION CENTER**

PROJECT ADDRESS

**2277 NAPA VALLEJO HWY
 NAPA, CA 94558**

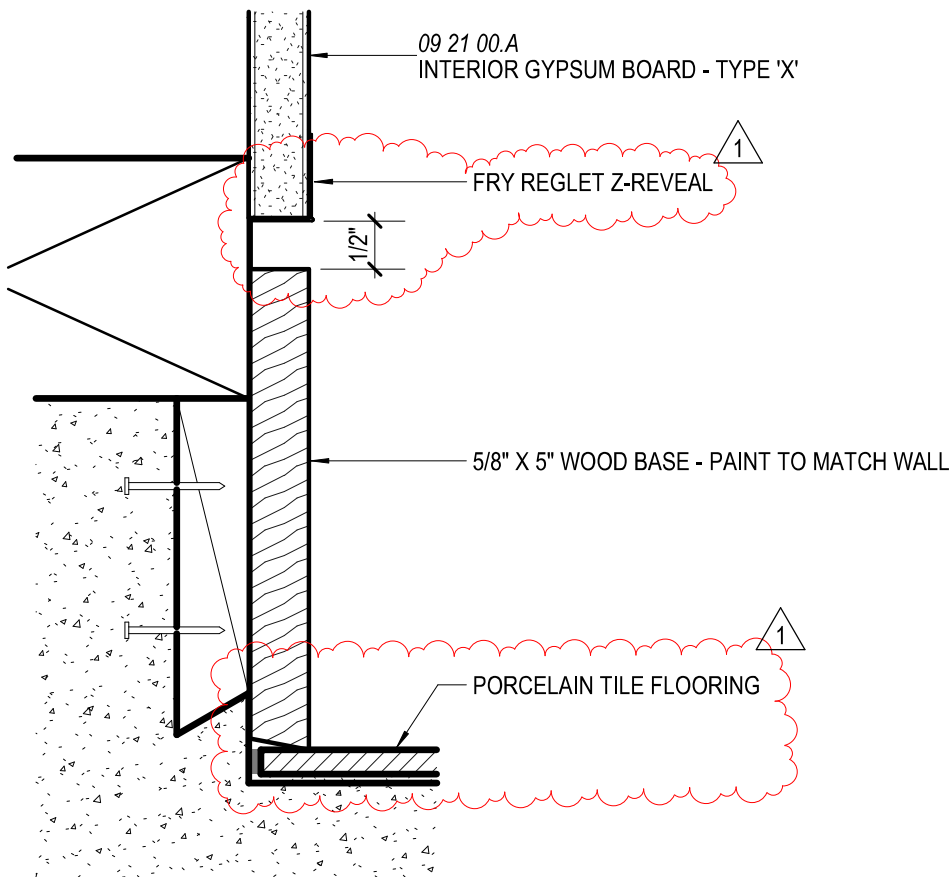

NO.	DATE	DESCRIPTION
1	3/6/24	ADDENDUM 1

TLCD PROJECT NO:

21062.00

DATE:

01/10/24

BY:

DSK

DESCRIPTION:

**WOOD BASE AT
 HOSPITALITY**

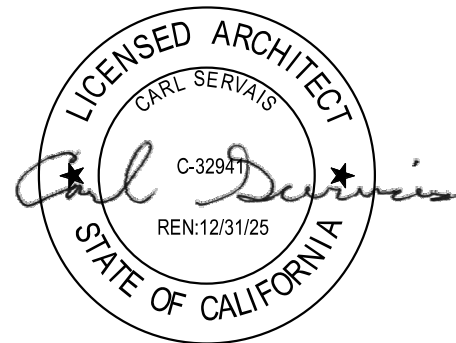

1

DRAWING NO:

ASK1-AD1